

m  
Materasso

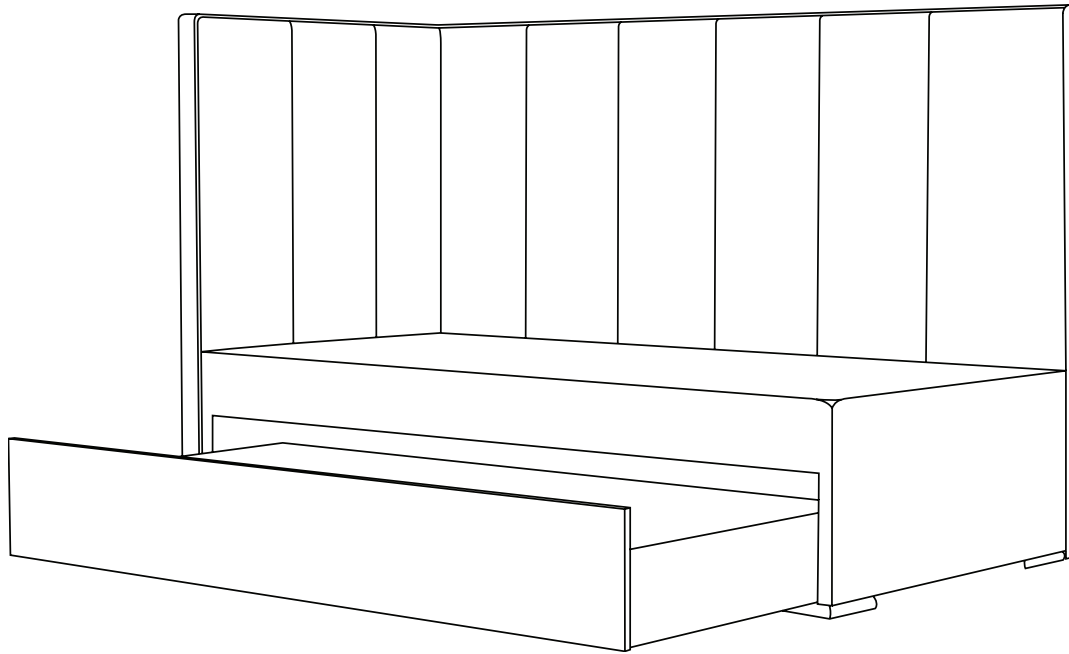

PL

**m**  
**Materasso**  
Dla tych, którzy kochają spanie...



- 15 DAMIANI SET
- 17 CRISTAL SET
- 19 SPECTRA SET
- 21 CORONA SET
- 23 FRANCESCA LUX SET
- 25 SOUL SET

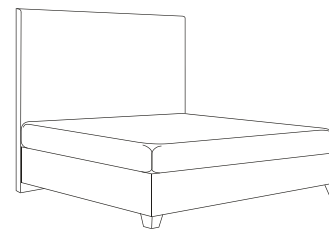

- 27 CHESS
- 29 ZINA
- 31 DUNA
- 33 CRISTAL
- 35 LA SPEZIA
- 37 DAMIANI
- 39 SOUL
- 41 CORIUM
- 43 FORREST
- 45 CHESTERFIELD
- 47 RHOMBUS
- 49 WILD
- 51 KINGSTONE
- 53 HONEY
- 54 MELVA
- 56 SPECTRA

- 58 HORIZONTAL
- 60 NAVY
- 62 ENIF
- 64 GEMINI
- 67 FRANCESCA LUX
- 69 CLAUDIA LUX
- 70 ALESIA
- 73 VEGA
- 75 BELLATRIX
- 76 ATLAS
- 78 CORONA
- 80 PARIS
- 82 VIENNA
- 84 NOBILIA
- 87 ARGENTINA
- 89 SIRIUS
- 91 VELORUM
- 93 CORIUM SLIDE
- 95 WALL
- 97 TWINS

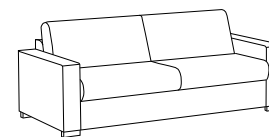

- 99 AMIRA
- 101 SIESTA
- 103 SOFABED BARI
- 105 SOFABED TORVI
- 107 SOFABED SINGLE
- 109 SOFABED DOUBLE

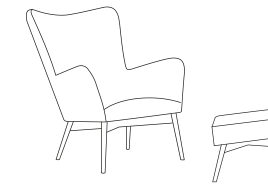

- 110 BOUDOIR MONT BLANC
- 111 MONT BLANC
- 112 BOSS
- 113 MOON
- 114 PUFF
- 116 BOUDOIR BREEZE
- 117 BREEZE
- 118 DE LUXE
- 119 MODERN
- 120 CUT
- 120 CASTELO
- 120 CROSS

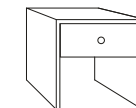

- 121 INDUSTRY
- 121 HEAVY OAK
- 121 OAK
- 122 WHITE
- 122 STONE
- 122 DARK STONE
- 123 CUBE
- 123 DAMIANI
- 123 BIANCA
- 124 TABURET | BENCH



Materasso sp. z o.o. to rodzinna firma obecna na rynku od ponad 30 lat.

Na rynku czeskim, europejskim, a w ostatnich latach także na rynkach pozaeuropejskich, znana jest z produkcji certyfikowanych materacy, designerskich łóżek, dodatków wnętrzarskich (pufy, fotele, szafki nocne...) oraz akcesoriów do łóżek (kołdry, poduszki, ochroniacze na materace).

Dzięki nieustannie poszerzanej ofercie produktów, wykorzystaniu wysokiej jakości materiałów, przestrzeganiu certyfikowanych procesów produkcyjnych i profesjonalnej obsłudze posprzedażowej zyskujemy coraz więcej zadowolonych klientów – zarówno indywidualnych, jak i profesjonalistów (projektantów wnętrz oraz hotelarzy).

Sypialnia jest najbardziej intymnym i najważniejszym miejscem w domu.

Jest to miejsce odpoczynku i relaksu dla ciała i wszystkich zmysłów po całodziennym wysiłku. Tam nabierasz sił i przygotowujesz się do nowych wyzwań.

Zdajemy sobie sprawę, że centralnym punktem sypialni jest łóżko, które nadaje jej duszę i charakter. Dlatego naszą kolekcję łóżek cechuje nie tylko solidna konstrukcja i perfekcyjne wykonanie, ale także piękny design, bogaty wybór tkanin obiciowych i ich kolorów.

W połączeniu z naszą ofertą materacy zapewni najwyższy poziom komfortu i wygody. Kładziemy duży nacisk na funkcjonalność i możliwość tworzenia modeli łóżek dokładnie według indywidualnych życzeń.

Dzięki dużej różnorodności kształtów i wzorów, a także kolorów i dodatkowych funkcji, w naszej ofercie na pewno znajdziesz łóżko, które dopełni styl wnętrza, dzięki czemu sypialnia stanie się najprzytulniejszym miejscem w Twoim domu.

Stawiamy na silny zespół wykwalifikowanych ekspertów z wieloletnim doświadczeniem w produkcji materacy i łóżek, a także na jakość naszych produktów.

Oferujemy możliwość łączenia różnych systemów łóżek z szeroką gamą nowoczesnych wezłowiów o różnym wzornictwie i sposobie wykonania.

Wykonujemy różnego rodzaju ramy łóżek z węższymi lub grubszymi ramami bocznymi, łóżka o standardowych i nietypowych długościach, a także komfortowe łóżka w wersjach boxspring, które są znane przede wszystkim z hoteli.

Klient może wybrać wersję z miejscem do przechowywania lub bez. Wybór stelaży jest również indywidualny, od klasycznych, poprzez uchyłne, aż po stelaże z napędem elektrycznym.

Stale śledzimy nowe technologie i trendy w projektowaniu wnętrz. Ich późniejsze zastosowanie w produkcji pozwoliło nam na stworzenie kompleksowej i udanej pod względem wzornictwa kolekcji łóżek i całych zestawów sypialnianych.

Design i styl łóżek podkreślają zastosowane wysokiej jakości tkaniny obiciowe. W naszej ofercie znajdują Państwo nie tylko tkaniny o oryginalnych wzorach i strukturach, ale także tkaniny ze specjalną ochroną ułatwiającą czyszczenie, tkaniny odporne na wchłanianie płynów i brudu.

Każde łóżko z oferty (o dowolnej konstrukcji korpusu) można precyzyjnie dopasować, wybierając odpowiednie nogi o różnych wzorach – pod względem materiału, kształtu i wysokości.



Opcje ułożenia materaca:

## 1. SYSTEM Z WNĘKĄ NA MATERAC:

Materac jest zagłębiony w ramie łóżka, co oznacza, że wymiary zewnętrzne łóżka są większe od wymiarów materaca.

Ta opcja jest możliwa tylko w przypadku łóżek ramowych.



## 2. SYSTEM CORIUM:

Materac umieszczany jest na stelażu (łóżko ramowe lub boxspring), przy czym wymiary zewnętrzne materaca są takie same jak wymiary korpusu łóżka.

## SYSTEMY ŁÓŻEK

Każdy system łóżka można łączyć z dowolnym wezglowiem i nozkami. Istnieje możliwość wyboru spośród szerokiej gamy wysokiej jakości tkanin obiciowych.

Do każdego łóżka można zamówić również pufę, fotel lub podnózek w tym samym materiale.

Wysokość systemów sypialnych podawana jest bez nóg. Wszystkie łóżka w programie dziecięcym i młodzieżowym produkujemy od szerokości 90 cm.

Cała rama łóżka (bez wezglowia i stelaży) jest zapakowana w karton, co ułatwia transport i zapewnia lepszą ochronę podczas przenoszenia.

Wszystkie połączenia ram korpusu wykonane są na nakrętki i śruby z gwintem metrycznym, co pozwala na bezproblemowy montaż.

## UŻYTE SKRÓTY:

UP – pojemnik na pościel  
BV – podnoszenie boczne  
NV – podnoszenie od strony nóg

NEW



## BOXSPRING SLIDE

Boxspring zaprojektowano z myślą o maksymalnym komforcie i funkcjonalności. Dzięki połączeniu sprężyn kieszeniowych i warstwy piany PUR 35 w górnej części materaca sprężynowego, zapewnia on optymalny komfort snu. Takie połączenie gwarantuje odpowiednie podparcie ciała i jednocześnie elastyczność, co przyczynia się do relaksującego i zdrowego snu.

Ten model łóżka typu boxspring jest idealnym wyborem dla osób ceniących sobie praktyczność wbudowanego dodatkowego łóżka, nie rezygnując przy tym z wygody. Liniowo rozkładane okucia

umożliwiają łatwą i płynną obsługę. Materac w dostawce możesz wybrać według własnych preferencji, maksymalna wysokość materaca wynosi 20 cm.

NEW



## HIGHLIGHT

Box obity jest tym samym materiałem co wezglowie, a powierzchnia spania korpusu pokryta jest specjalnym materiałem z wykończeniem ANTYPOŚLIZGOWYM, który doskonale zabezpiecza materac przed przesuwaniem. Wysokość boku boxu wynosi 10 cm.



### BOXSPRING 22-32 CM

Jest to najbardziej zaawansowany system łóżek. Jego popularność wynika ze specyficznej konstrukcji: masywna rama otacza wkład sprężynowy, który tworzy punktową bazę pod materacem, poprawiając właściwości kopiowania i ogólną adaptację zastosowanego materaca. Kompozycja ta tworzy wyjątkowy system podwójnego kopiowania naturalnego kształtu ciała.

Łóżko typu boxspring obite jest tym samym materiałem co wezglowie, a na powierzchni łóżka naszyty jest specjalny materiał z wykończeniem ANTYPOŚLIZGOWYM, który doskonale zabezpiecza materac przed przesuwaniem. Wysokość boku łóżka wynosi 22 lub 32 cm. Materac nie jest osadzony w ramie łóżka, lecz jest położony na równo z korpusem.



### BOXSPRING UP VYKLOP MAXI

UP MAXI 40, UP MAXI 100, a także UP MAXI ELECTRIC to idealne rozwiązanie dla osób poszukujących wygodnego łóżka z zaletami boxspringu, uzupełnionego o dużą przestrzeń do przechowywania wewnątrz łóżka. Konstrukcja łóżka pozwala na zmniejszenie ilości miejsca w sypialni i pozwala na użycie większego materaca w porównaniu do tradycyjnego typu łóżka.

Pojemnik na pościel bez wewnętrznych przegródek zapewnia wyjątkowo dużą przestrzeń magazynowania z doskonałym dostępem z każdej strony. Boxspring UP MAXI 40 z łatwością uniesie materac o łącznej wadze do 40 kg. System UP MAXI 100 jest przeznaczony do cięższych materacy. Posiada 4 mocowania i siłowniki do łatwego podnoszenia pokrywy schowka wraz z ciężkimi materacami. Pokrywa pojemnika w opcji UP MAXI ELECTRIC podnoszona jest za pomocą mechanizmu elektrycznego. Wysokość stelaża wynosi 32 cm.



### UP WOOD

Jest to rozwiązanie dla osób, które potrzebują więcej miejsca do przechowywania w sypialni i wolą korzystać z jednego wspólnego materaca. Rama łóżka ma grubość 3, 5 lub 8 cm i wysokość 30 lub 35 cm.

Konstrukcja i stelaż wykonane są z masywnego drewna bukowego. Łóżko podnoszone od przodu za pomocą siłowników pneumatycznych, co ułatwia dostęp do pojemnika na pościel, nawet w przypadku stosowania ciężkich materacy.



### UP METAL

Jest to rozwiązanie dla osób, które potrzebują więcej miejsca do przechowywania w sypialni i wolą korzystać z jednego wspólnego materaca. Rama łóżka ma grubość 3, 5 lub 8 cm i wysokość 30 lub 35 cm.

Wyposażono je w specjalny stelaż z listew na metalowej konstrukcji, podnoszony z przodu łóżka za pomocą siłowników pneumatycznych, co ułatwia dostęp do pojemnika na pościel, nawet w przypadku stosowania ciężkich materacy. Metalowa rama stelaża wyposażona jest w listwy elastyczne. Dzięki zdjęciu dolnej płyty schowka zyskujemy dostęp pod całą powierzchnię łóżka, co docenić można zwłaszcza podczas sprzątania.



### UP METAL LIFT-UP

Udoskonaleniem UP metal jest METAL LIFT-UP, który ułatwia dostęp do pojemnika na pościel w obszarze węzłowania łóżka, a także znacznie upraszcza zmianę pościeli.



### UP BV | UP NV

Łóżka designerskie UP BV i UP NV posiadają składane stelaże drewniane. Aby w pełni wykorzystać składane stelaże, do tego łóżka zaleca się użycie dwóch oddzielnych materacy. Przy zastosowaniu stelaży METAL, DOBLE NV i DOUBLE BV materac jest wgłębiony o 6 cm od górnej krawędzi ramy.

W wersji Corium stelaże mogą być zamontowane na wysokości bocznej krawędzi korpusu, a materace układane są zarówno na stelażach jak i na ramie korpusu. Takie łóżko będzie sprawiało wrażenie boxspringu, a szerokość łóżka (łącznie z bokami) będzie taka sama jak szerokość materaca.



### BEZ MIEJSCA DO PRZECHOWYWANIA

Designerskie łóżko zostało zaprojektowane dla tych, którzy nie potrzebują miejsca do przechowywania rzeczy w łóżku. Rama łóżka jest podobna do ramy łóżka z funkcją podnoszenia, ale nie zawiera mocowania.

Korpus ten jest przystosowany do wszystkich rodzajów stelaży: od prostych stelaży, poprzez stelaże twarde, stelaże elastyczne, manualnie regulowane, aż po modele z płynną regulacją elektryczną. Dla absolutnego komfortu podczas snu, ale także dla chwil aktywnego relaksu, np. czytania. Produkujemy ramy łóżka o różnych grubościach boku: 3, 5 lub 8 cm i trzech wysokościach: 15, 30 lub 35 cm.



### BOXSPRING MOBIL

Konstrukcja łóżka jest identyczna jak w przypadku boxspringu 32 i uzupełniona jest o funkcję płynnej regulacji położenia głowy, pleców i nóg za pomocą silnika elektrycznego z pilotem. Ten typ łóżka nie posiada wystających ram bocznych, pozwala na ustawienie najlepszej pozycji do odpoczynku. Inna jest pozycja do spania, inna do aktywnego wypoczynku (np. czytania), a jeszcze inna do regeneracji obolałych nóg.

Boxspring Mobil sprawdza się idealnie w połączeniu z materacami z zimnej pianki, wkładami materacy profilowanymi i wyciętymi, materacy lateksowych, a także materacy wykonanych z „leniwych” pianek termoelastycznych.

Tego typu materace po ustawieniu dokładnie dopasowują się do kształtu stelaża. Wysokość stelaża wynosi 32 cm.

## KOMPLETY ŁÓŻEK, TAPICERKA ŚCIENNA I AKCESORIA

Nowością, która spotyka się z uznaniem nie tylko projektantów wnętrz i hotelarzy, ale coraz częściej również zwykłych konsumentów, jest możliwość zamówienia do naszych łóżek pufy, szafek nocnych, fotela lub podnóżka w tej samej tkaninie obciowej, co łóżko.

Dla tych, którzy już posiadają wysokiej jakości łóżko (np. z litego drewna) i planują upiększyć wnętrze swojej sypialni, oferujemy możliwość łączenia ze sobą poszczególnych akcesoriów w tej samej tkaninie obciowej lub dopasowania ich do tapicerki ściany za wezgłowiem łóżka. SET (kombinacja) łóżka i wszystkich lub wybranych akcesoriów w identycznej tkaninie obciowej podnosi ogólne wrażenie designu Twojej sypialni, tworzy pożądane poczucie elegancji i luksusu oraz jest odzwierciedleniem wyjątkowego gustu i preferencji.





# DAMIANI SET

NEW

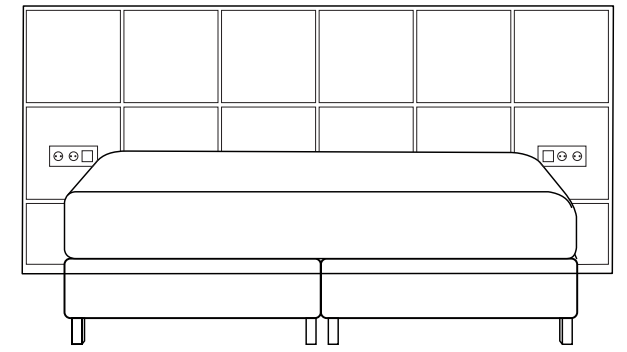

DAMIANI  
(p. 37)

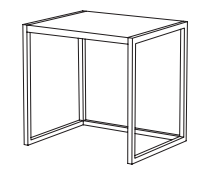
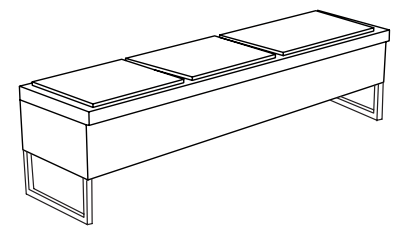

DAMIANI  
(p. 123)





# CRISTAL SET

NEW

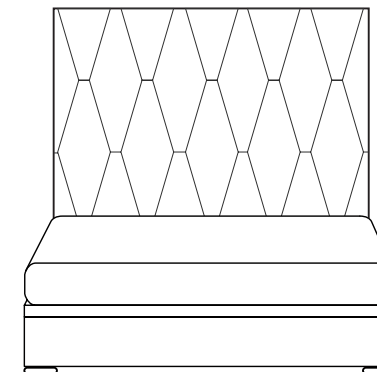

**CRISTAL**  
(p. 33)

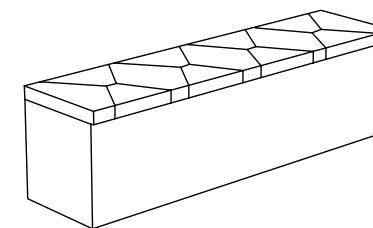

**TABURET**  
No. 5 (p. 125)

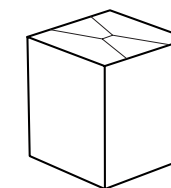

**CUBE - CRISTAL**  
(p. 123)



# SPECTRA SET

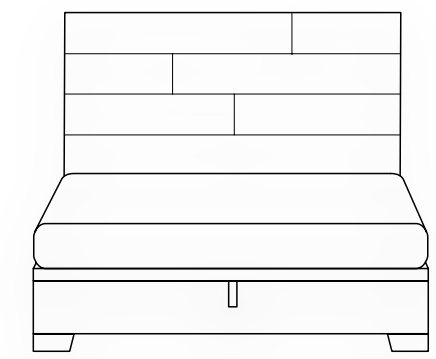

**SPECTRA**  
(p. 56)

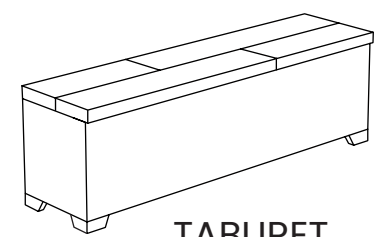

**TABURET**  
No. 7 (p. 125)

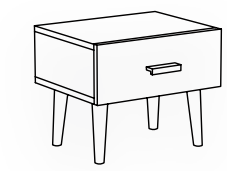

**BIANCA**  
(p. 123)

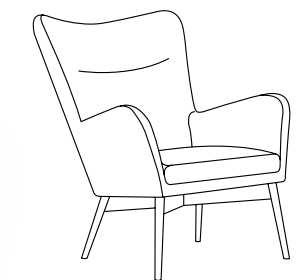

**BREEZE**  
(p. 117)

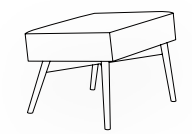

**CUT**  
(p. 120)



# CORONA SET

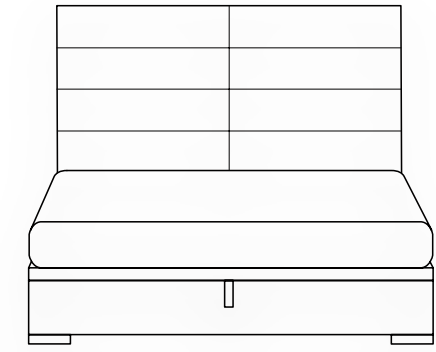

**CORONA**  
(p. 78)

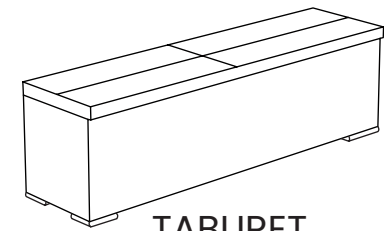

**TABURET**  
No. 4 (p. 125)

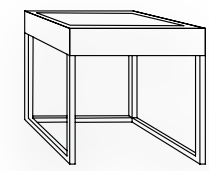

**INDUSTRY**  
(p. 121)

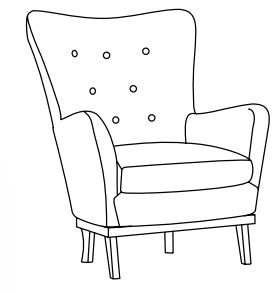

**DE LUXE**  
(p. 118)

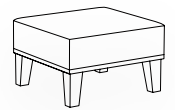

**CASTELO**  
(p. 120)



# FRANCESCA LUX SET

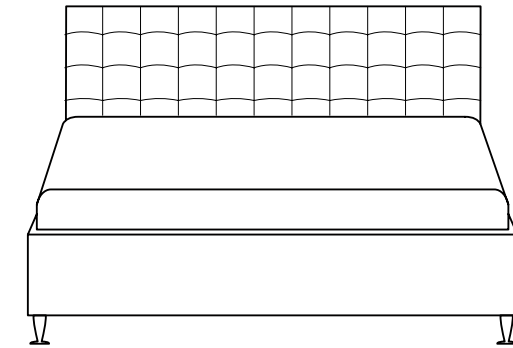

**FRANCESCA LUX**  
(p. 67)

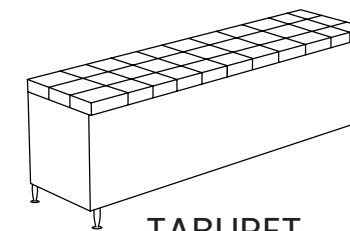

**TABURET**  
No. 12 (p. 125)

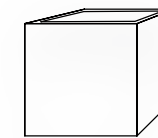

**CUBE**  
(p. 123)

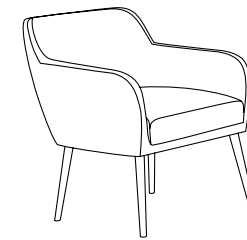

**MODERN**  
(p. 119)



**CROSS**  
(p. 120)



# SOUL SET

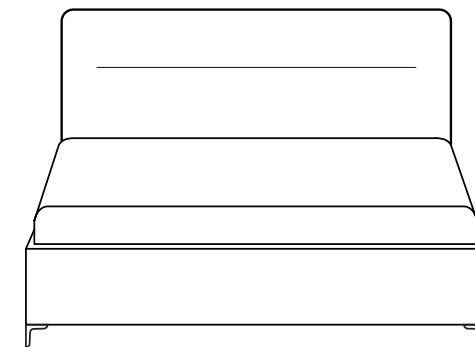

**SOUL**  
(p. 39)

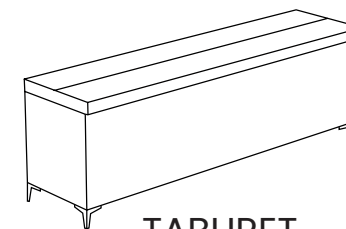

**TABURET**  
No. 1; 3 (p. 125)

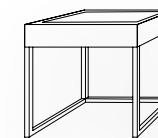

**INDUSTRY**  
(p. 121)

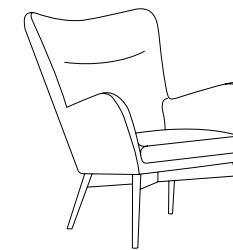

**BREEZE  
MIRACH**  
(p. 117)



**CROSS**  
(p. 120)



# CHESS

NEW

	L	b <sup>l</sup>	b <sup>w</sup>	b <sup>h</sup>	h <sup>w</sup>	h <sup>h</sup>	m <sup>l</sup>	m <sup>w</sup> (cm)
DESING BED	211	205	190	30	270	130	200	180

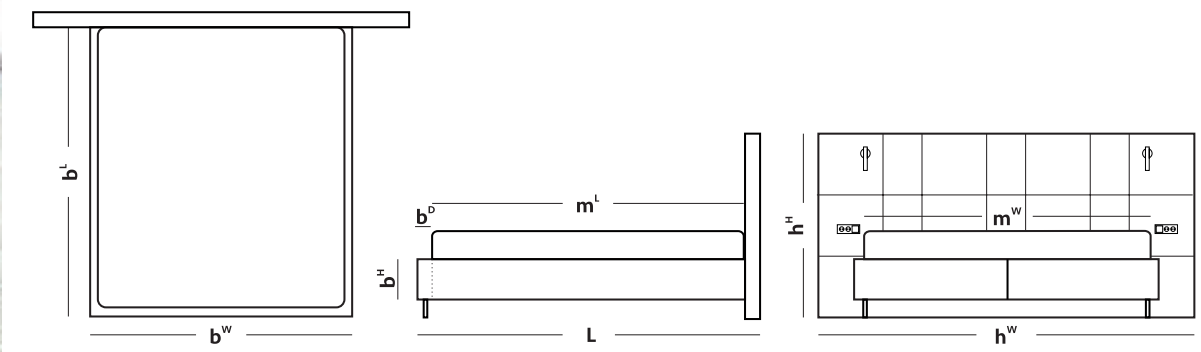



# ZINA

NEW

	L	b <sup>l</sup>	b <sup>w</sup>	b <sup>h</sup>	h <sup>w</sup>	h <sup>h</sup>	m <sup>l</sup>	m <sup>w</sup> (cm)
DESING BED	204	200	180	10	316	139	200	180

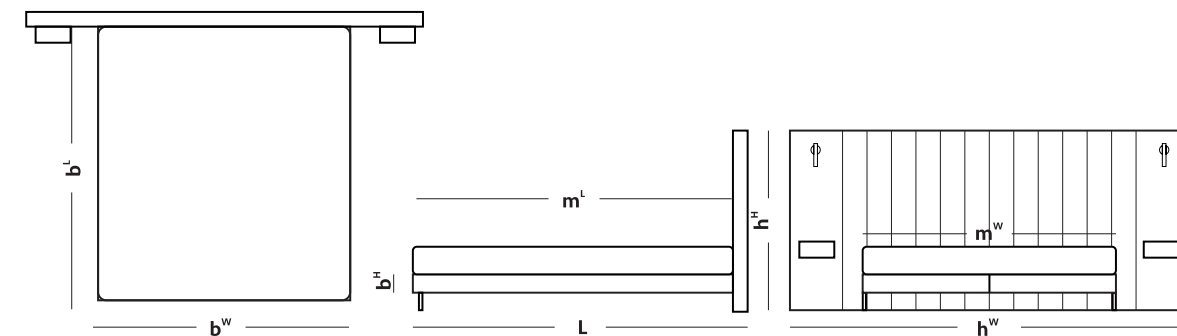



# DUNA

NEW

	L	b <sup>l</sup>	b <sup>w</sup>	b <sup>h</sup>	h <sup>w</sup>	h <sup>h</sup>	m <sup>l</sup>	m <sup>w</sup> (cm)
DESING BED	211	205	190	30	190	111	200	180

Taburet  
(p. 125)

No. 10

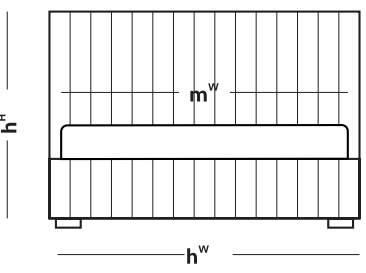
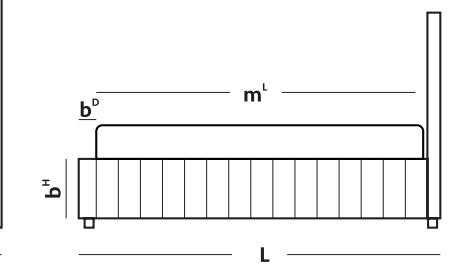
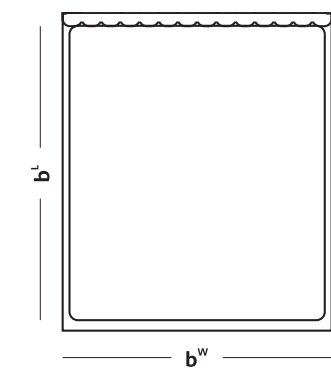
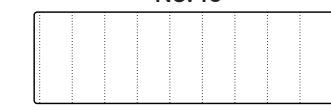





# CRISTAL

	L	b <sup>l</sup>	b <sup>w</sup>	b <sup>h</sup>	h <sup>w</sup>	h <sup>h</sup>	m <sup>l</sup>	m <sup>w</sup> (cm)
Maxi Elektro 32	208	200	180	32	180	160	200	180

Taburet  
(p. 125)

No. 5

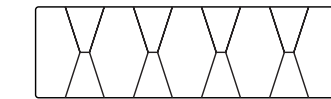

No. 1

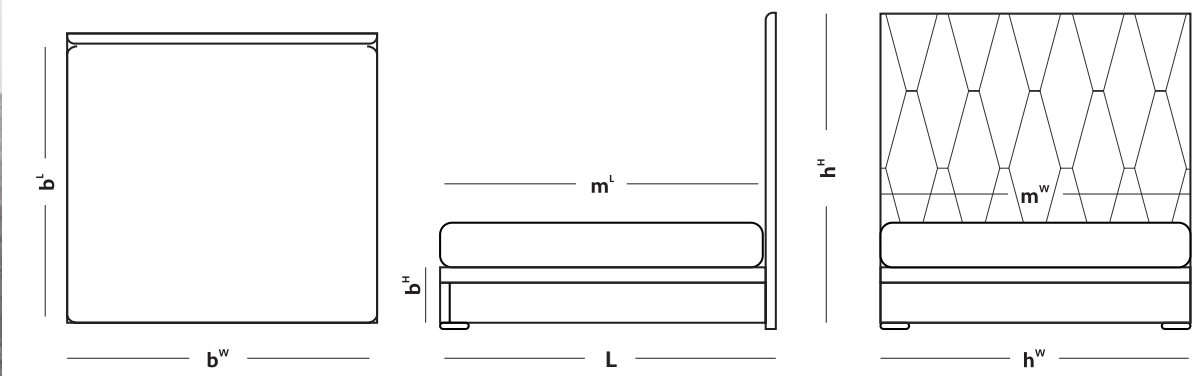



# LA SPEZIA

NEW

	L	b <sup>L</sup>	b <sup>W</sup>	b <sup>H</sup>	h <sup>W</sup>	h <sup>H</sup>	m <sup>L</sup>	m <sup>W</sup> (cm)
DESING BED	213	203	186	35	246	135	200	180

Taburet  
(p. 125)

No. 1

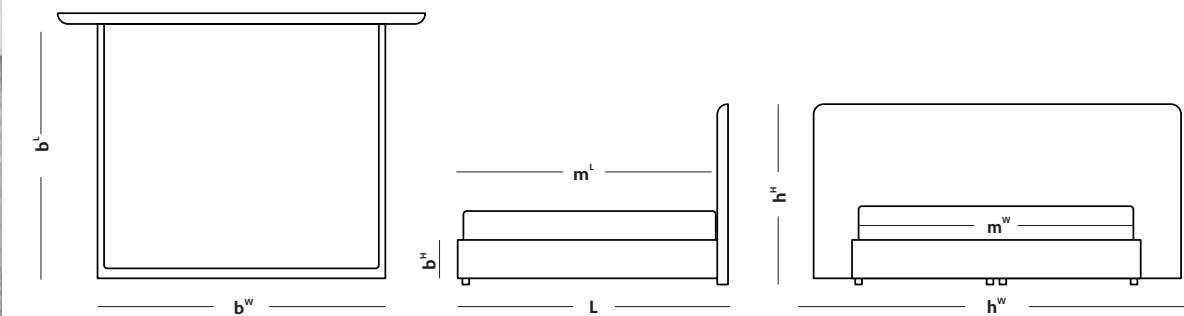



Width 74.0"



17 gal  
19 hwy

Front 265/35 ZR 20  
Rear 325/30 ZR 21

# DAMIANI

NEW

	L	b <sup>L</sup>	b <sup>W</sup>	b <sup>H</sup>	h <sup>W</sup>	h <sup>H</sup>	m <sup>L</sup>	m <sup>W</sup> (cm)
<b>BOXSPRING 22</b>	207	200	180	22	272	122	200	180

Taburet  
(p. 124)

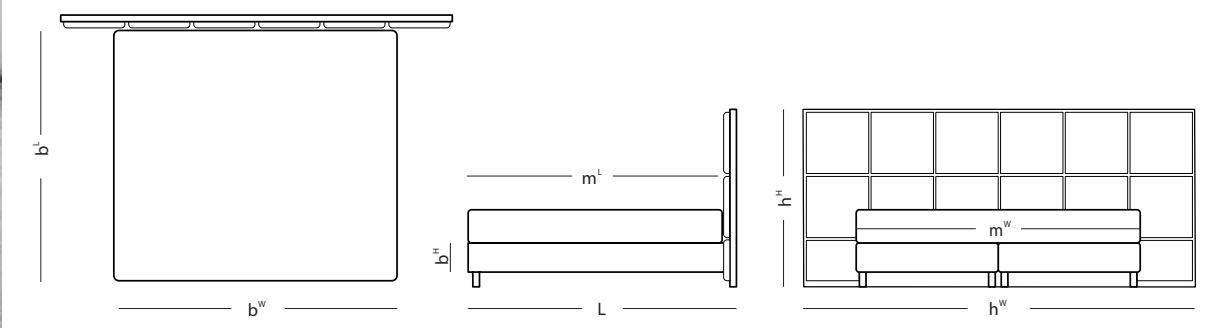
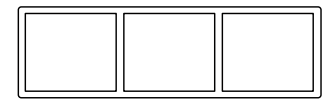



# SOUL

NEW

	L	b <sup>l</sup>	b <sup>w</sup>	b <sup>h</sup>	b <sup>d</sup>	h <sup>w</sup>	h <sup>h</sup>	m <sup>l</sup>	m <sup>w</sup> (cm)
DESING BED	216	205	190	35	5	196	120	200	180
TYPE CORIUM	211	200	180	35	5	186	120	200	180

Taburet  
(p. 125)

No. 1

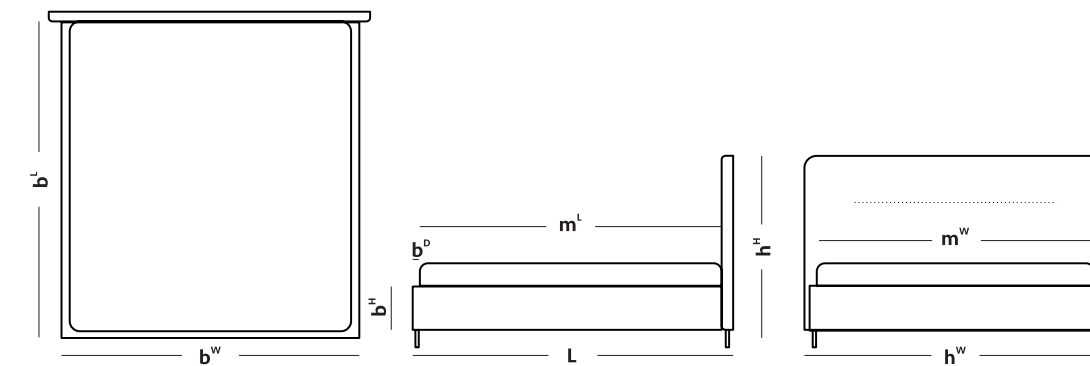



# CORIUM

	L	b <sup>l</sup>	b <sup>w</sup>	b <sup>h</sup>	h <sup>w</sup>	h <sup>h</sup>	m <sup>l</sup>	m <sup>w</sup> (cm)
DESING BED	209	200	180	30	180	150	200	180
CORIUM	209	200	160	30	160	150	200	160

Taburet  
(p. 125)

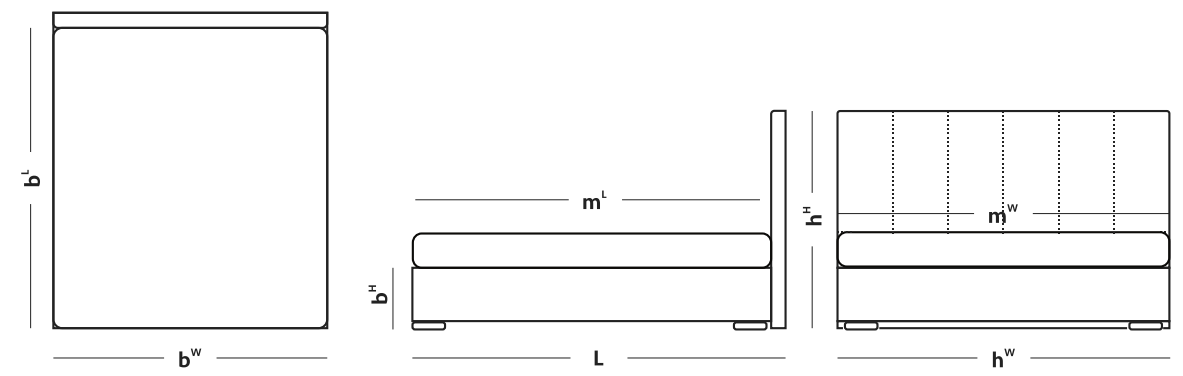
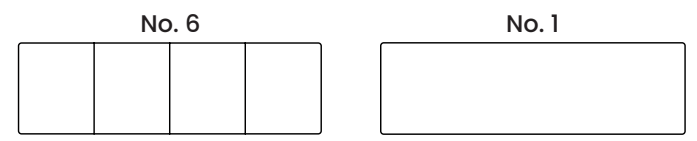



# FORREST

	L	b <sup>l</sup>	b <sup>w</sup>	b <sup>h</sup>	h <sup>w</sup>	h <sup>h</sup>	m <sup>l</sup>	m <sup>w</sup> (cm)
<b>BOXSPRING 32</b>	208	200	180	32	180	160	200	180
	208	200	160	32	160	160	200	160

Taburet  
(p. 125)

No. 1



No. 18

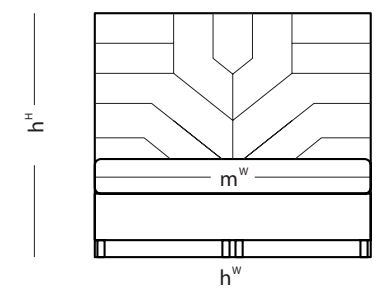
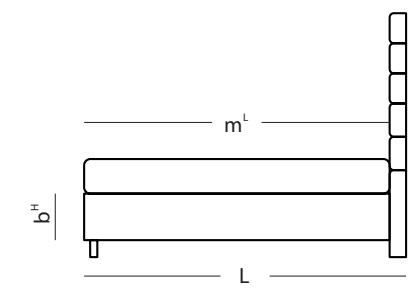
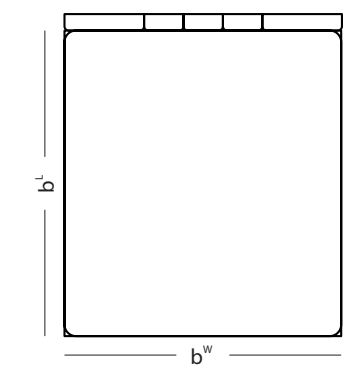
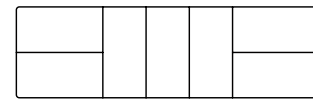



# CHESTERFIELD

	L	b <sup>L</sup>	b <sup>W</sup>	b <sup>H</sup>	h <sup>W</sup>	h <sup>H</sup>	m <sup>L</sup>	m <sup>W</sup> (cm)
<b>BOXSPRING 22</b>	213	200	180	22	180	143	200	180
	213	200	160	22	160	143	200	160

Taburet  
(p. 125)

No. 1

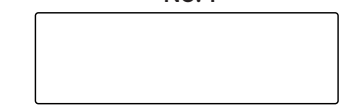

No.17

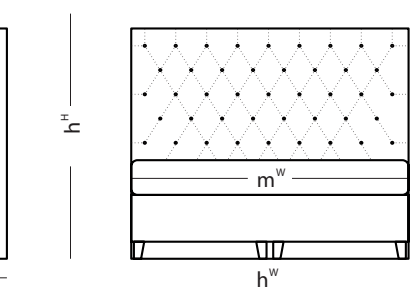
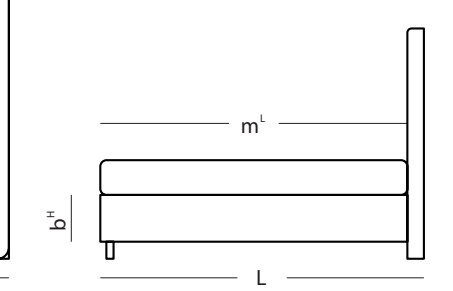
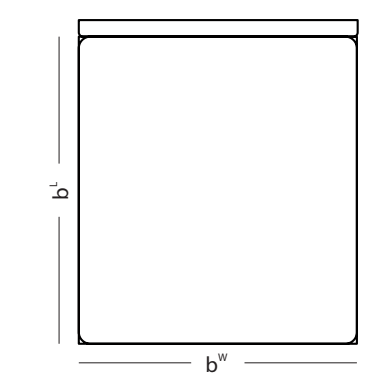
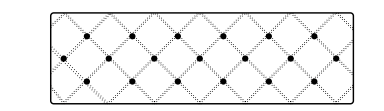



# RHOMBUS

	L	b <sup>L</sup>	b <sup>W</sup>	b <sup>H</sup>	h <sup>W</sup>	h <sup>H</sup>	m <sup>L</sup>	m <sup>W</sup> (cm)
<b>BOXSPRING 32</b>	208	200	180	32	180	160	200	180
	208	200	160	32	160	160	200	160

Taburet  
(p. 125)

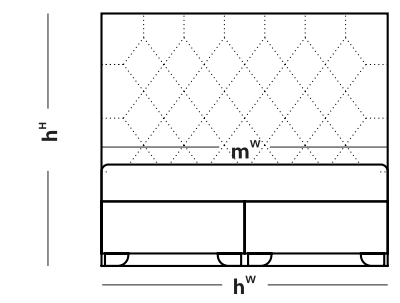
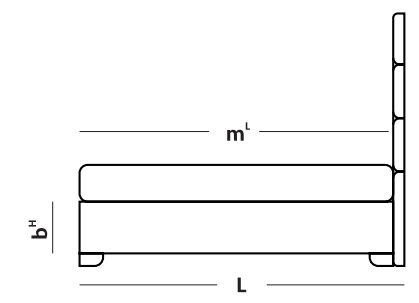
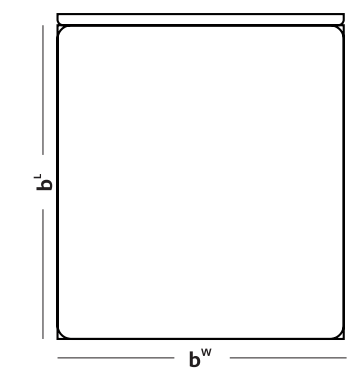
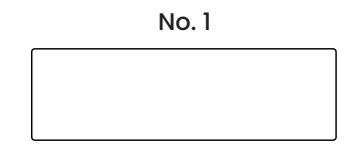
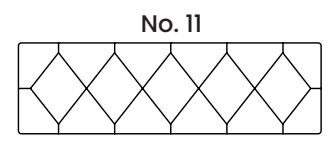





# WILD

	L	b <sup>L</sup>	b <sup>W</sup>	b <sup>H</sup>	h <sup>W</sup>	h <sup>H</sup>	m <sup>L</sup>	m <sup>W</sup> (cm)
<b>BOXSPRING 32</b>	208	200	180	32	180	160	200	180
	208	200	160	32	160	160	200	160

Taburet  
(p. 125)

No. 16

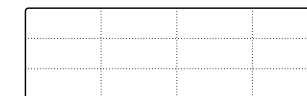

No. 1

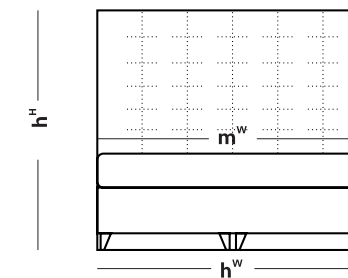
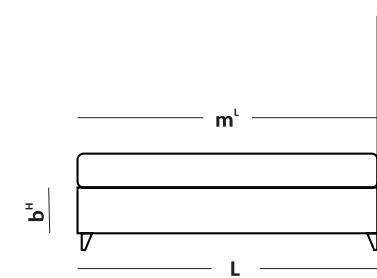
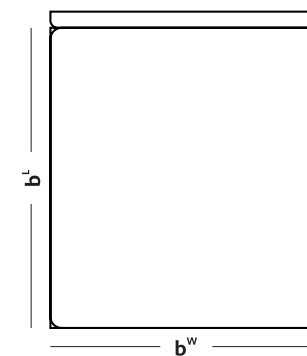



# KINGSTONE

	L	b <sup>L</sup>	b <sup>W</sup>	b <sup>H</sup>	b <sup>D</sup>	h <sup>W</sup>	h <sup>H</sup>	m <sup>L</sup>	m <sup>W</sup> (cm)
DESIGN BED	218	205	190	35	5	190	120	200	180
	218	205	170	35	5	170	120	200	160

Taburet  
(p. 125)

No. 2

No. 1

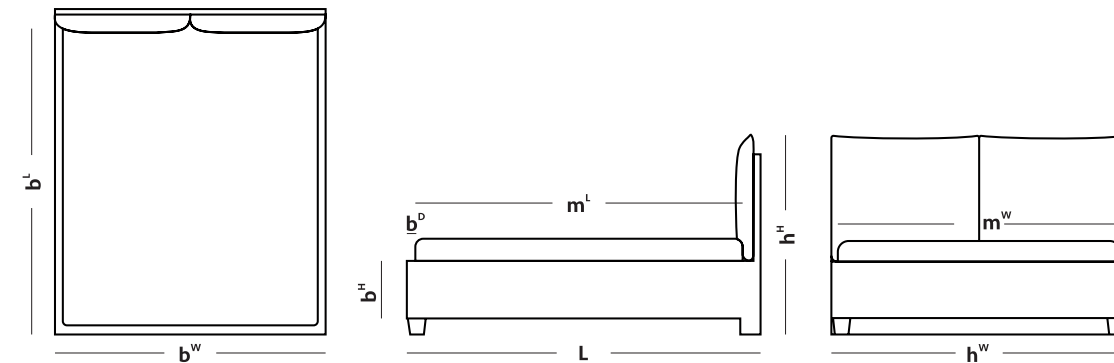
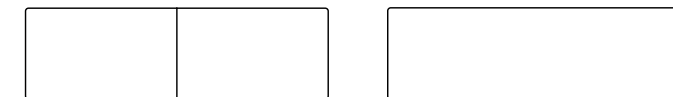



# HONEY

	L	b <sup>L</sup>	b <sup>W</sup>	b <sup>H</sup>	b <sup>D</sup>	h <sup>W</sup>	h <sup>H</sup>	m <sup>L</sup>	m <sup>W</sup> (cm)
DESIGN BED	213	205	190	35	5	190	160	200	180
	213	205	170	35	5	170	160	200	160

Taburet  
(p. 125)

No. 8

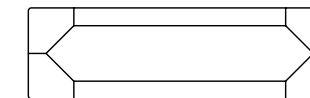

No. 1

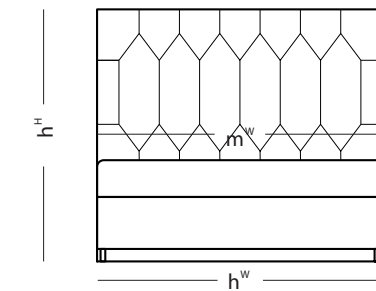
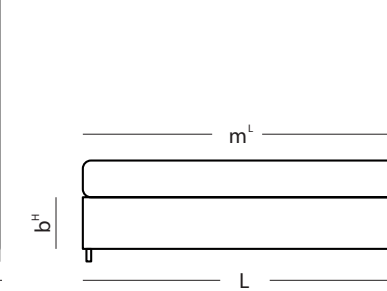
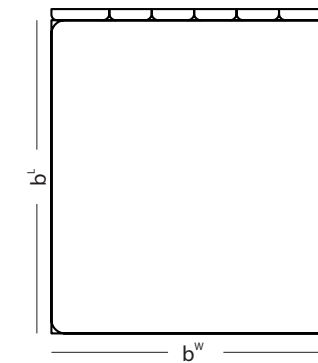

# MELVA

	L	b <sup>l</sup>	b <sup>w</sup>	b <sup>h</sup>	h <sup>w</sup>	h <sup>h</sup>	m <sup>l</sup>	m <sup>w</sup> (cm)
<b>BOXSPRING 32</b>	208	200	180	32	186	160	200	180
	208	200	160	32	166	160	200	160

Taburet  
(p. 125)

No. 13

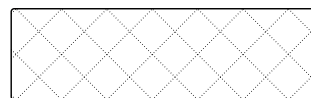

No. 1

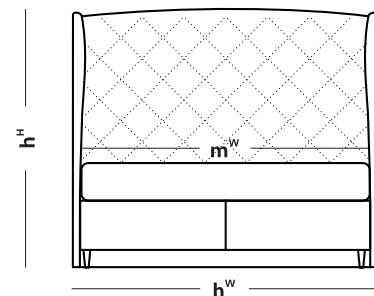
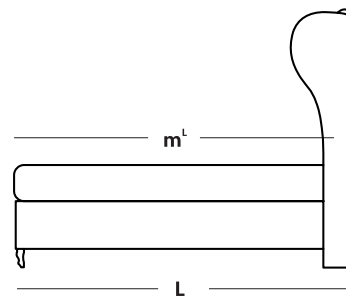
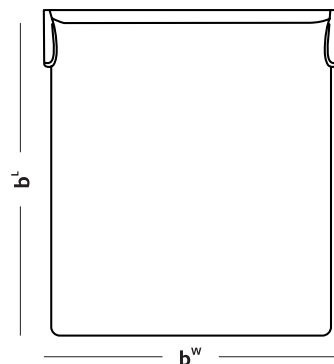

# SPECTRA

	L	b <sup>l</sup>	b <sup>w</sup>	b <sup>h</sup>	h <sup>w</sup>	h <sup>h</sup>	m <sup>l</sup>	m <sup>w</sup> (cm)
MAXI	208	200	180	32	180	130	200	180
	208	200	160	32	160	130	200	160

Taburet  
(p. 125)

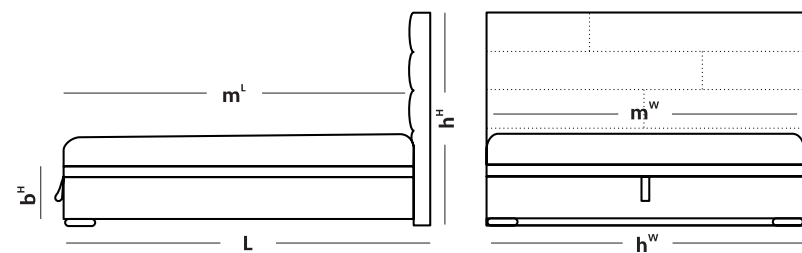
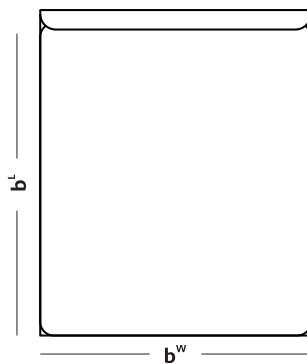
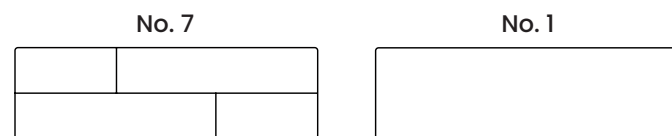

# HORIZONTAL

	L	b <sup>L</sup>	b <sup>W</sup>	b <sup>H</sup>	h <sup>W1</sup>	h <sup>W2</sup>	h <sup>H</sup>	m <sup>L</sup>	m <sup>W</sup> (cm)
<b>MAXI</b>	210	200	180	32	180	240	145	200	180
	210	200	160	32	160	220	145	200	160

Taburet  
(p. 125)

No. 3

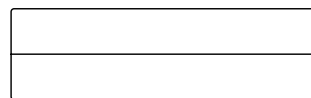

No. 1

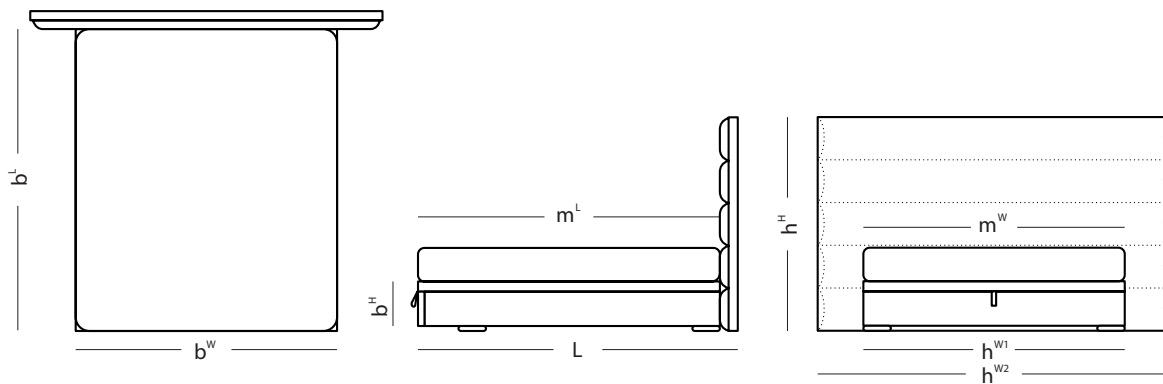

# NAVY

	L	b <sup>L</sup>	b <sup>W</sup>	b <sup>H</sup>	b <sup>D</sup>	h <sup>W</sup>	h <sup>H</sup>	m <sup>L</sup>	m <sup>W</sup> (cm)
DESIGN BED	213	205	190	30	5	190	123	200	180
	213	205	170	30	5	170	123	200	160

Taburet  
(p. 125)

No. 1

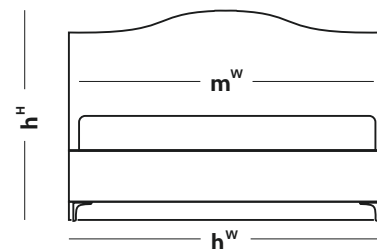
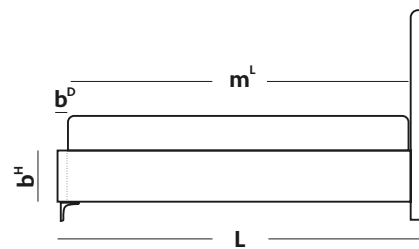
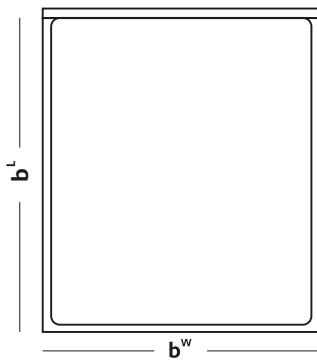

# ENIF

	L	b <sup>L</sup>	b <sup>W</sup>	b <sup>H</sup>	b <sup>D</sup>	h <sup>W</sup>	h <sup>H</sup>	m <sup>L</sup>	m <sup>W</sup> (cm)
DESIGN BED	213	205	190	35	5	196	123	200	180
	213	205	170	35	5	176	123	200	160

Taburet  
(p. 125)

No. 1

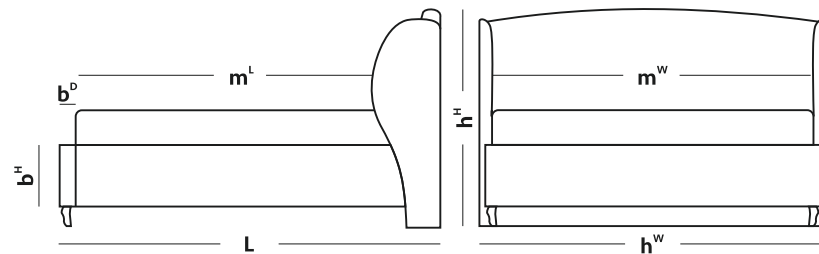
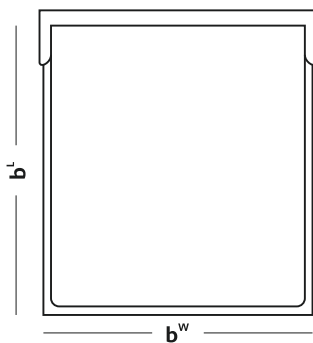



# GEMINI

	L	b <sup>l</sup>	b <sup>w</sup>	b <sup>h</sup>	b <sup>p</sup>	h <sup>w</sup>	h <sup>h</sup>	m <sup>l</sup>	m <sup>w</sup> (cm)
DESIGN BED	213	205	190	30	5	190	150	200	180
	213	205	170	30	5	170	150	200	160

Taburet  
(p. 125)

No. 6

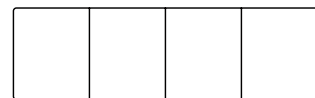

No. 1

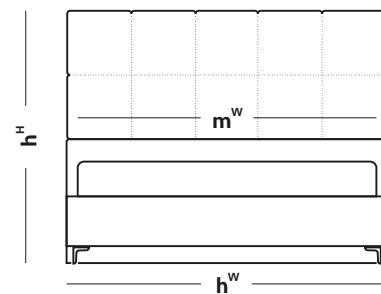
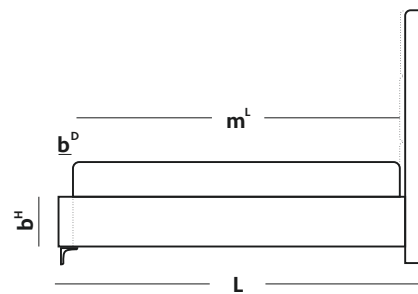
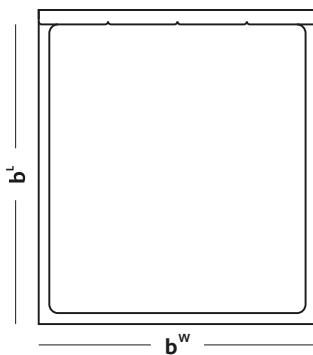



# FRANCESCA LUX

	L1   L2	b <sup>L</sup>	b <sup>W</sup>	b <sup>H</sup>	b <sup>D</sup>	h <sup>W</sup>	h <sup>H</sup>	m <sup>L</sup>	m <sup>W</sup> (cm)
DESIGN BED	231   216	205	190	30	5	190	103	200	180
	231   216	205	170	30	5	170	103	200	160

Taburet  
(p. 125)

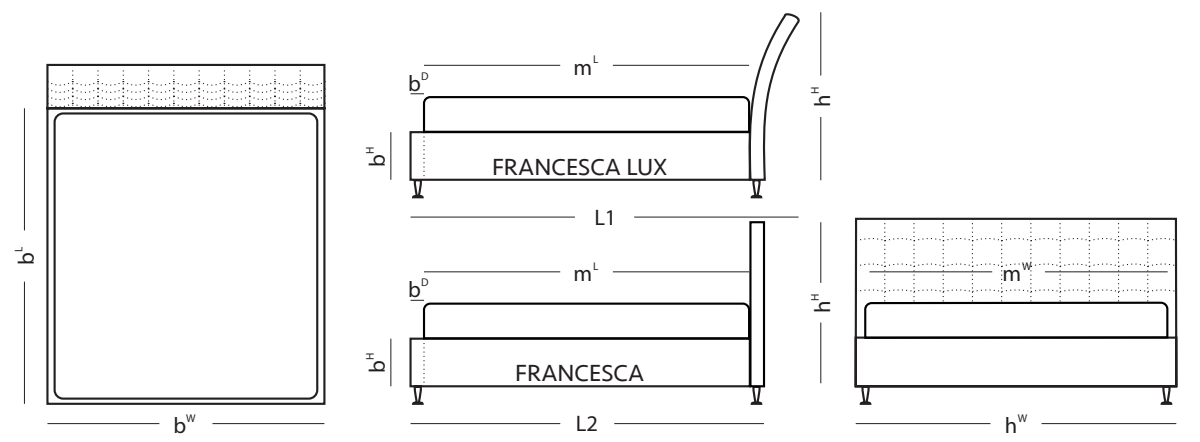
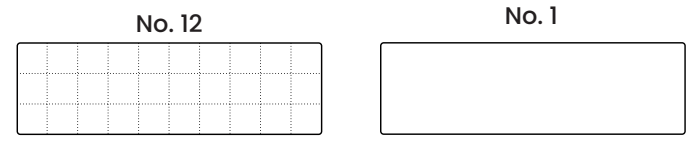



# CLAUDIA LUX

	L1   L2	b <sup>L</sup>	b <sup>W</sup>	b <sup>H</sup>	b <sup>D</sup>	h <sup>W</sup>	h <sup>H</sup>	m <sup>L</sup>	m <sup>W</sup> (cm)
DESIGN BED	234   219	208	196	30	8	196	103	200	180
	234   219	208	176	30	8	176	103	200	160

Taburet  
(p. 125)

No. 16

No. 1

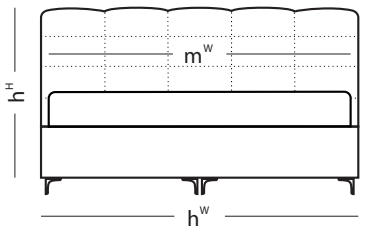
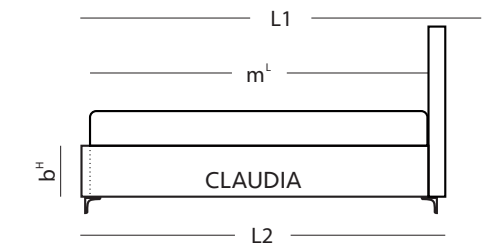
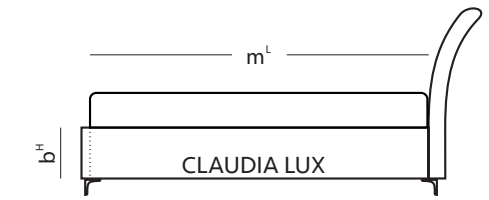
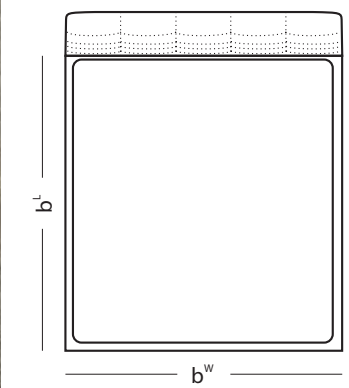

# ALESIA

	L	b <sup>L</sup>	b <sup>W</sup>	b <sup>H</sup>	b <sup>D</sup>	h <sup>W</sup>	h <sup>H</sup>	m <sup>L</sup>	m <sup>W</sup> (cm)
DESIGN BED	217	205	190	30	5	190	103	200	180
	217	205	170	30	5	170	103	200	160

Taburet  
(p. 125)

No. 13



No. 1

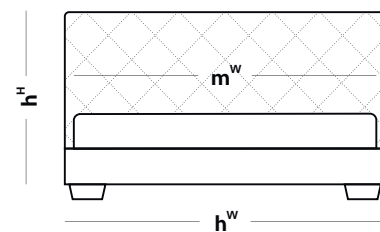
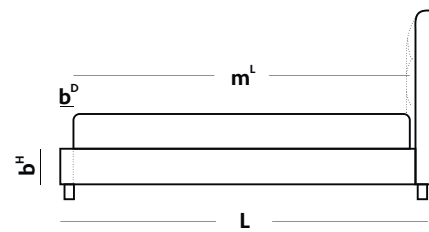
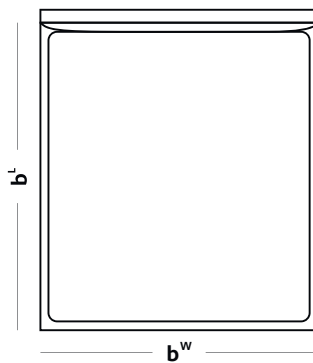



# VEGA

	L	b <sup>L</sup>	b <sup>W</sup>	b <sup>H</sup>	b <sup>D</sup>	h <sup>W</sup>	h <sup>H</sup>	m <sup>L</sup>	m <sup>W</sup> (cm)
DESIGN BED	213	205	190	30	5	190	130	200	180
	213	205	170	30	5	170	130	200	160

Taburet  
(p. 125)

No. 6

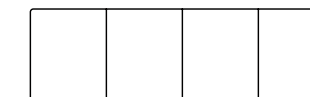

No. 1

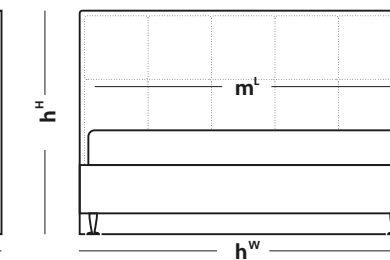
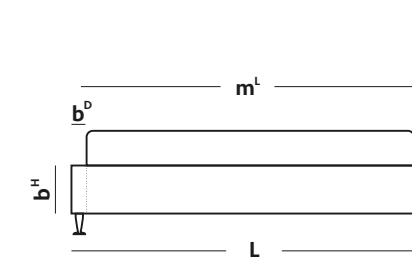
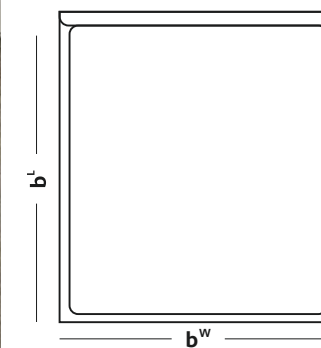



# BELLATRIX

	L	b <sup>L</sup>	b <sup>W</sup>	b <sup>H</sup>	b <sup>D</sup>	h <sup>W</sup>	h <sup>H</sup>	m <sup>L</sup>	m <sup>W</sup> (cm)
DESIGN BED	213	205	190	35	5	190	120	200	180
	213	205	170	35	5	170	120	200	160

Taburet  
(p. 125)

No. 10

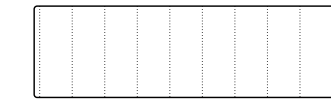

No. 1

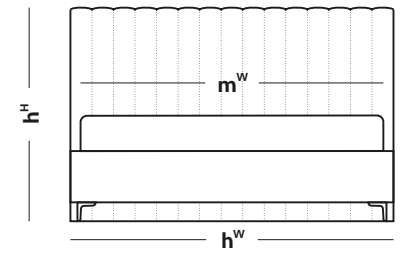
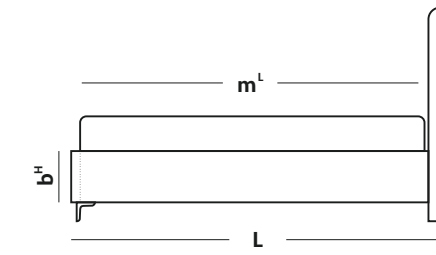
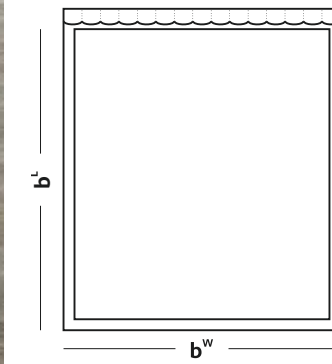

# ATLAS

	L	b <sup>l</sup>	b <sup>w</sup>	b <sup>h</sup>	h <sup>w</sup>	h <sup>h</sup>	m <sup>l</sup>	m <sup>w</sup> (cm)
BOXSPRING 22	225	200	180	22	180	100	200	180
	225	200	160	22	160	100	200	160

Taburet  
(p. 125)

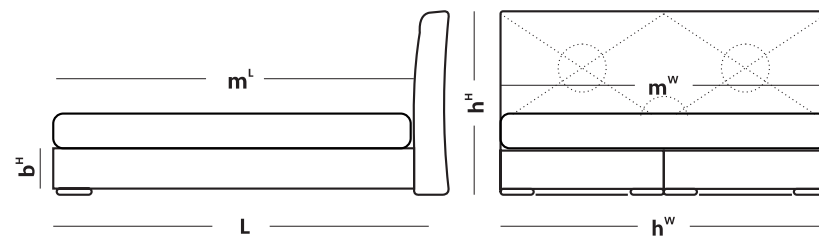
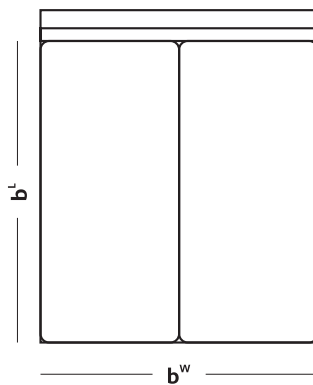
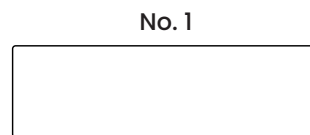
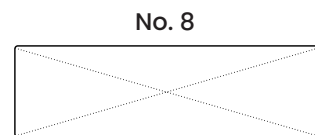

# CORONA

	L	b <sup>l</sup>	b <sup>w</sup>	b <sup>h</sup>	h <sup>w</sup>	h <sup>h</sup>	m <sup>l</sup>	m <sup>w</sup> (cm)
<b>MAXI</b>	208	200	180	32	180	120	200	180
	208	200	160	32	160	120	200	160

Taburet  
(p. 125)

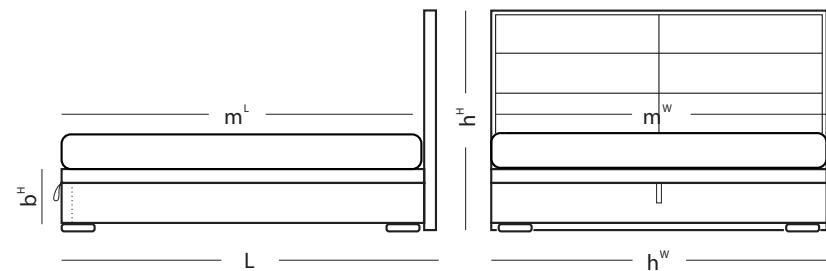
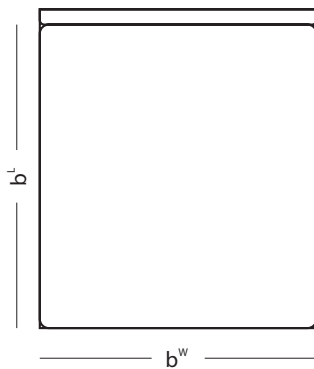
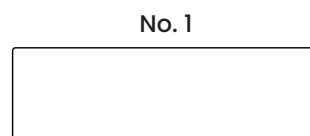
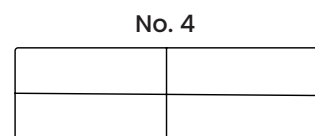



# PARIS

	L	b <sup>L</sup>	b <sup>W</sup>	b <sup>H</sup>	h <sup>W</sup>	h <sup>H</sup>	m <sup>L</sup>	m <sup>W</sup> (cm)
<b>BOXSPRING 32</b>	208	200	180	32	180	197	200	180
<b>+ COVER</b>	208	200	160	32	160	197	200	160

Taburet  
(p. 125)

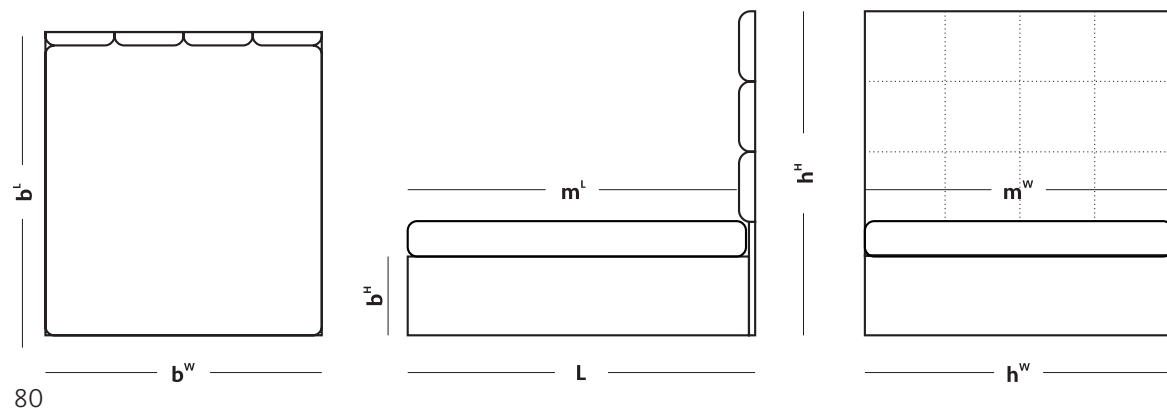
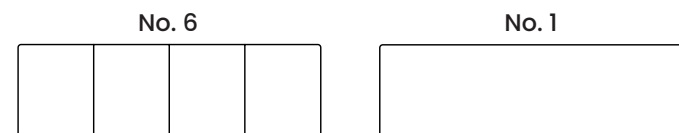

# VIENNA

	L	b <sup>L</sup>	b <sup>W</sup>	b <sup>H</sup>	h <sup>W</sup>	h <sup>H</sup>	m <sup>L</sup>	m <sup>W</sup> (cm)
BOXSPRING 32	208	200	180	32	190	160	200	180
	208	200	160	32	170	160	200	160

Taburet  
(p. 125)

No. 15

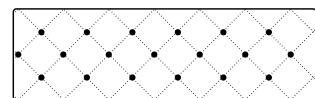

No. 1

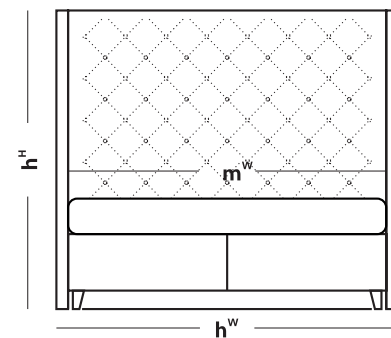
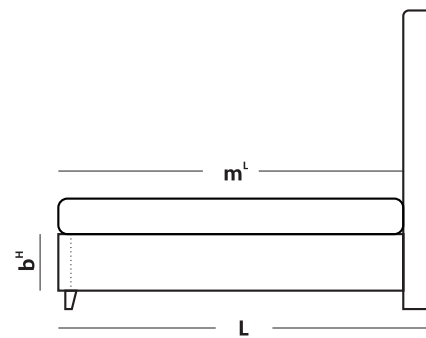
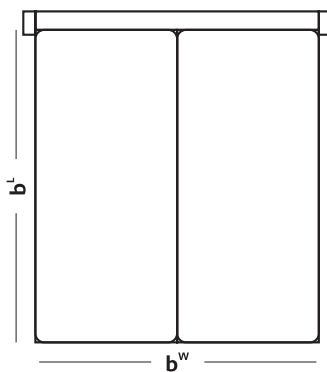

# NOBILIA

	L	b <sup>L</sup>	b <sup>W</sup>	b <sup>H</sup>	b <sup>D</sup>	h <sup>W</sup>	h <sup>H</sup>	m <sup>L</sup>	m <sup>W</sup> (cm)
DESIGN BED	213	205	190	30	5	190	120	200	180
	213	205	170	30	5	170	120	200	160

Taburet  
(p. 125)

No. 9



No. 1

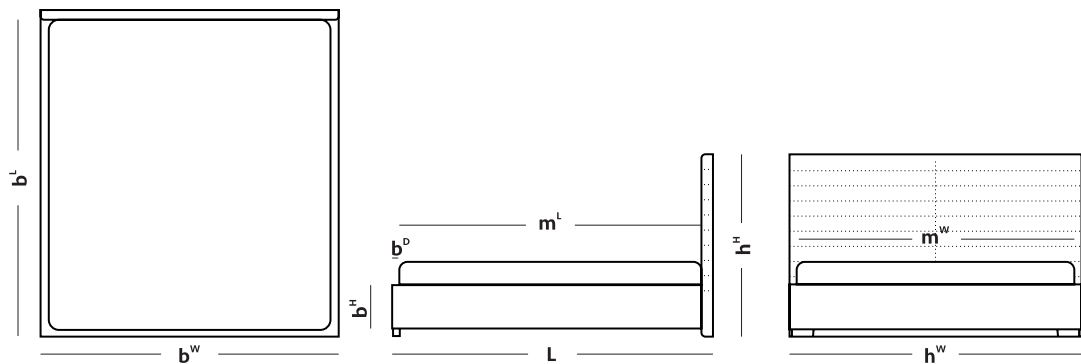



# ARGENTINA

	L	b <sup>L</sup>	b <sup>W</sup>	b <sup>H</sup>	b <sup>D</sup>	h <sup>W</sup>	h <sup>H</sup>	m <sup>L</sup>	m <sup>W</sup> (cm)
DESIGN BED	213	205	190	35	5	190	120	200	180
	213	205	170	35	5	170	120	200	160

Taburet  
(p. 125)

No. 1

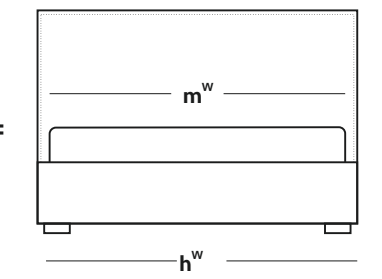
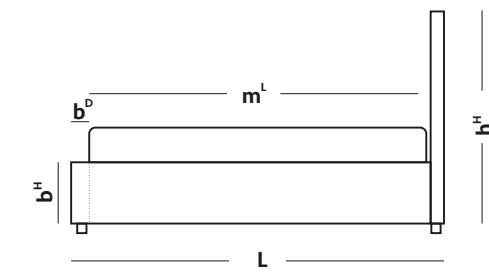
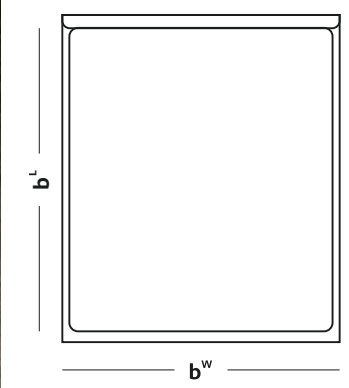



# SIRIUS

	L	b <sup>L</sup>	b <sup>W</sup>	b <sup>H</sup>	h <sup>W</sup>	h <sup>H</sup>	m <sup>L</sup>	m <sup>W</sup> (cm)
<b>BOXSPRING MOBIL</b>	208	200	180	32	180	120	200	180
	208	200	160	32	160	120	200	160

Taburet  
(p. 125)

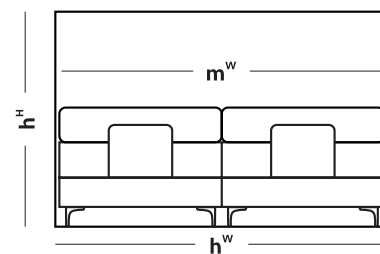
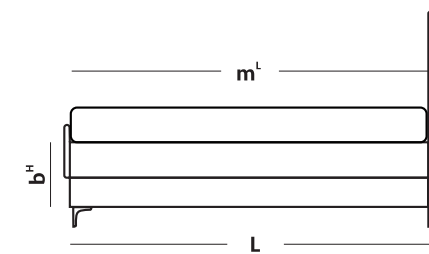
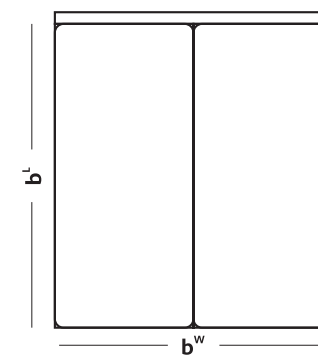
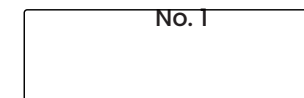



# VELORUM

	L	b <sup>L</sup>	b <sup>W</sup>	b <sup>H</sup>	h <sup>W</sup>	h <sup>H</sup>	m <sup>L</sup>	m <sup>W</sup> (cm)
<b>BOXSPRING 32</b>	208	200	180	32	180	120	200	180
	208	200	160	32	160	120	200	160

Taburet  
(p. 125)

No. 14

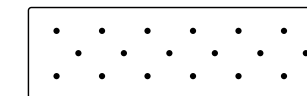

No. 1

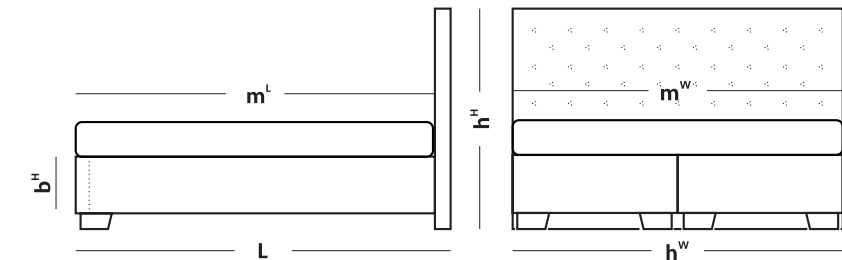
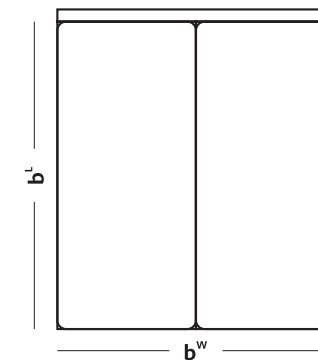



# CORIUM SLIDE

NEW

	L	b <sup>L</sup>	b <sup>W</sup>	b <sup>H</sup>	h <sup>W</sup>	h <sup>H</sup>	m <sup>L</sup>	m <sup>W</sup> (cm)
<b>BOXSPRING</b>	210	200	95	46	105	120	200	95
<b>Slide</b>							185	90

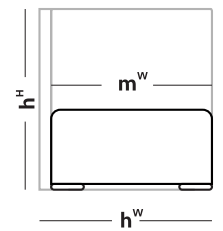
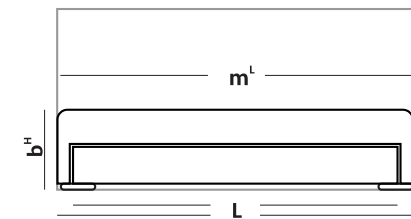
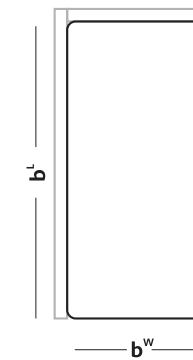



# WALL

NEW

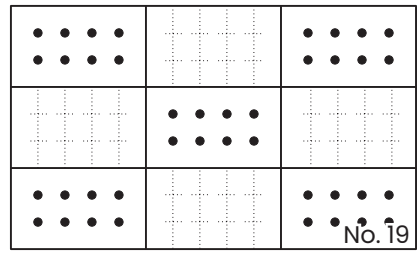
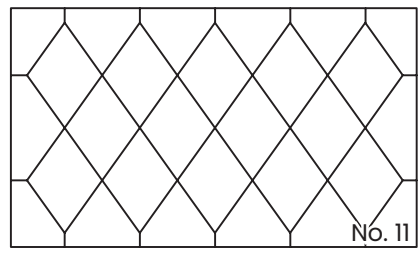
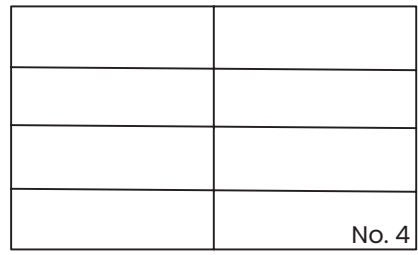
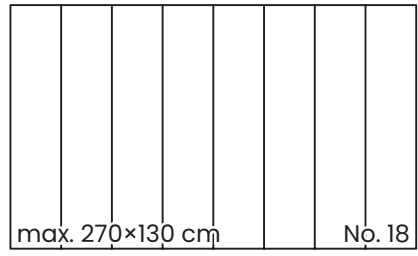
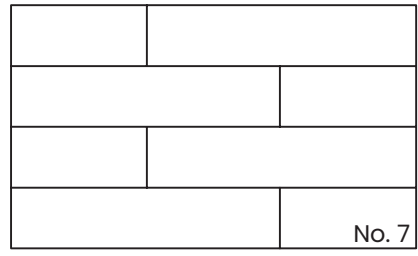
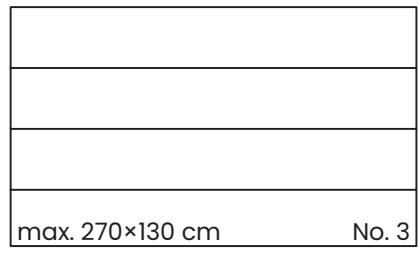
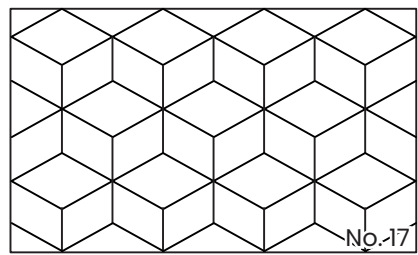
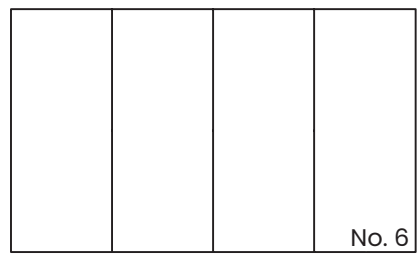
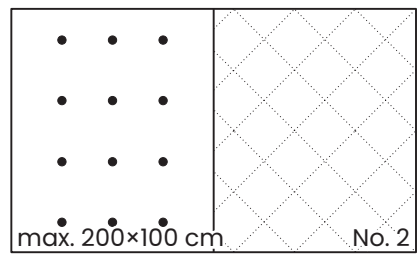





# TWINS

NEW

L	b <sup>w</sup>	b <sup>H</sup>	b <sup>H1</sup>	b <sup>H2</sup>	m <sup>L</sup>	m <sup>w</sup> (cm)
224	100	197	30	154	200	90

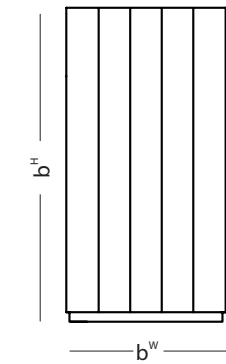
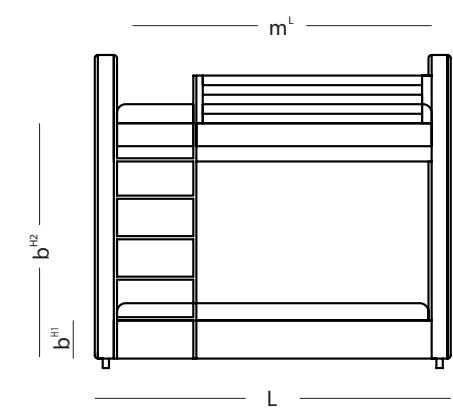
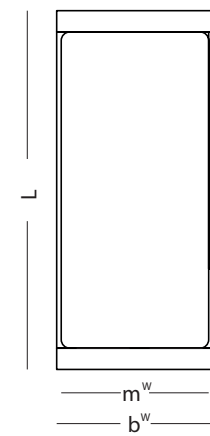

NEW



# AMIRA

L	b	h	L <sup>r</sup>	h <sup>r</sup>	L <sup>w</sup>	h <sup>w</sup> (cm)
200	80/90	22 - 45	70	23	80/90	28

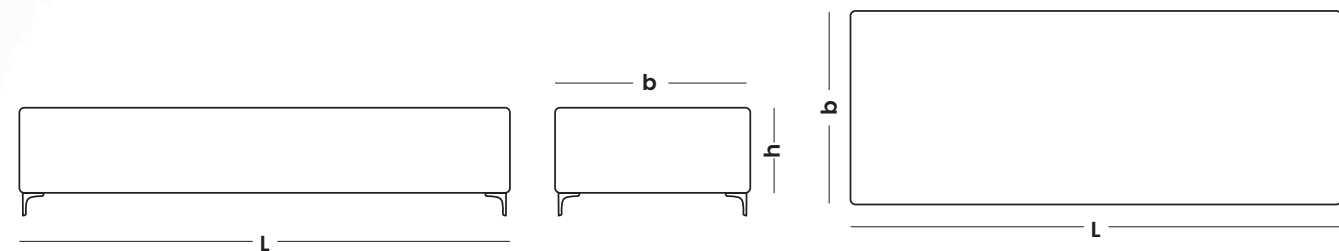
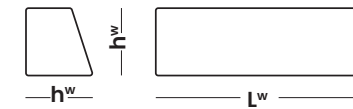
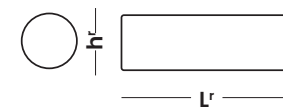

NEW



# SIESTA

a	b	c	d	e	f	g	h	L (cm)
80	88	40	75	14	5	60	86	188

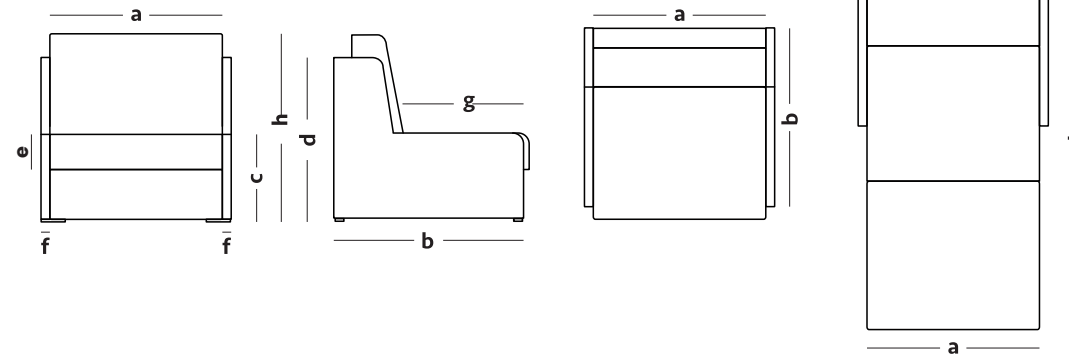

NEW



# SOFABED BARI

	a	b	c	d	e	f	g	m <sup>l</sup>	m <sup>w</sup>	L (cm)
<b>BARI DOUBLE</b>	210	49	68	100	62	30	152	190	140	240
<b>BARI TRIPLE</b>	230	49	68	100	62	30	172	190	160	240

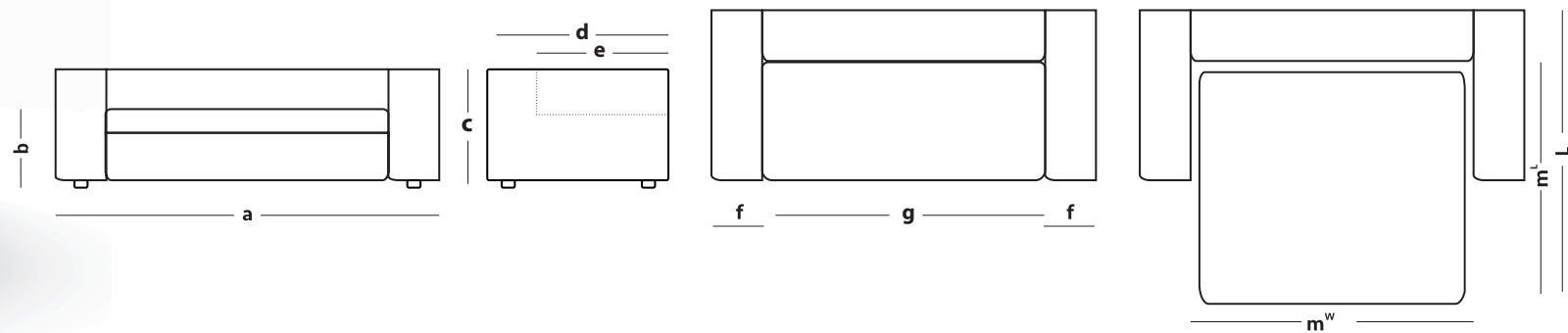

NEW



# SOFABED TORVI

	a	b	c	d	e	f	g	h	m <sup>l</sup>	m <sup>w</sup>	L (cm)
SOFABED DOUBLE	163	93	55	56	183	10	60	96	190	140	215
SOFABED TRIPLE	183	93	55	56	203	10	60	96	190	160	215

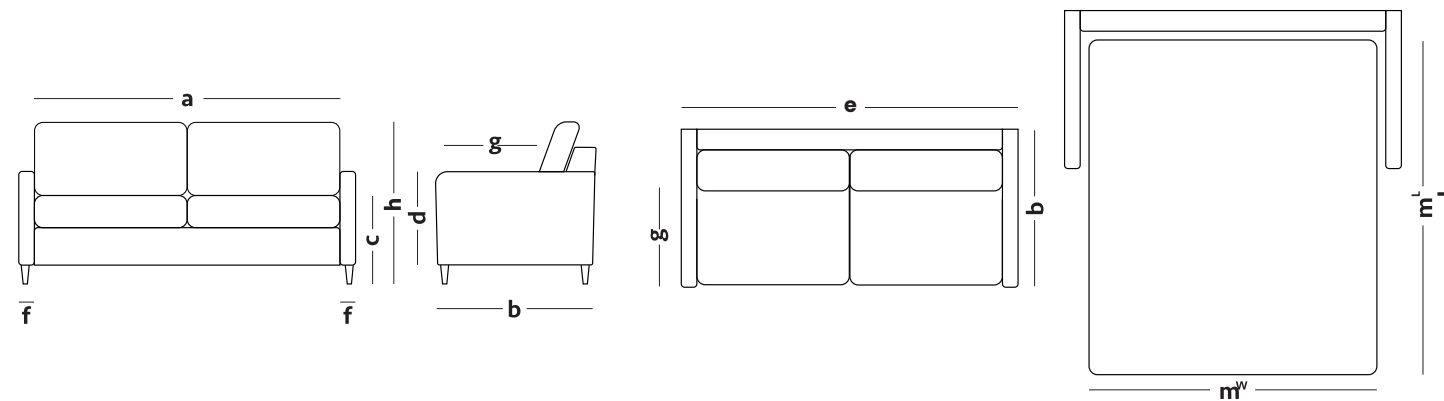



# SOFABED SINGLE

a	b	c	d	f	g	h	m <sup>l</sup>	m <sup>w</sup>	L	(cm)
80	98	48	60	13 17 21	55	85	190	80	215	

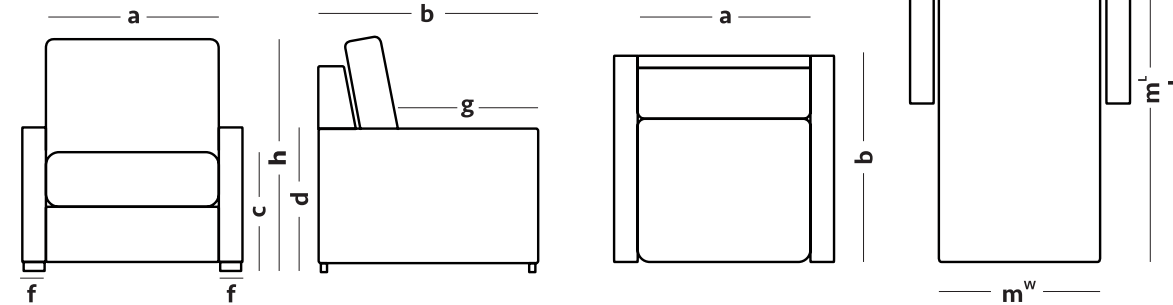



# SOFABED DOUBLE

	a	b	c	d	f	g	h	m <sup>l</sup>	m <sup>w</sup>	L (cm)
SOFABED DOUBLE	163	98	48	60	13 17 21	55	85	190	140	215
SOFABED TRIPLE	183	98	48	60	13 17 21	55	85	190	160	215

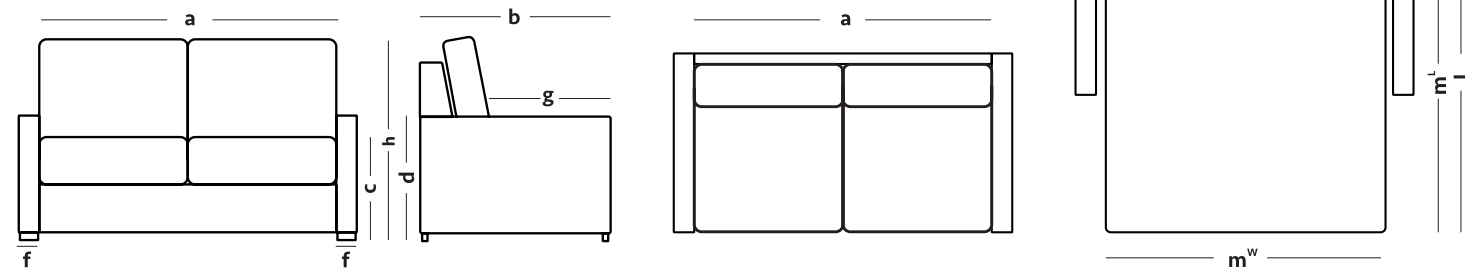

# BOUDOIR MONT BLANC

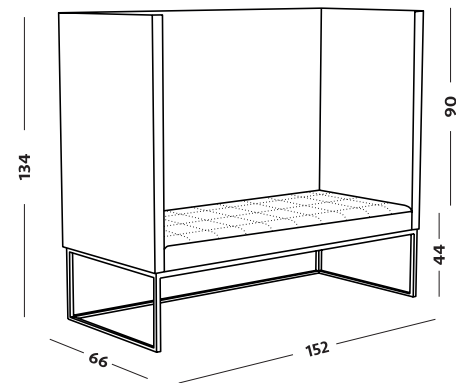

# MONT BLANC

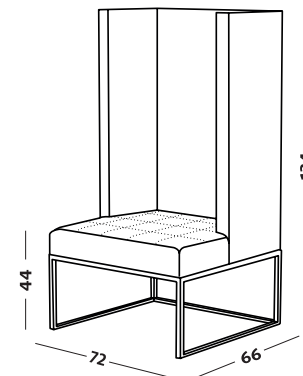



NEW

# BOSS



a	b	c	d	e	f	g	h	i	(cm)
50	50	105	95	50	50	78	95	30	

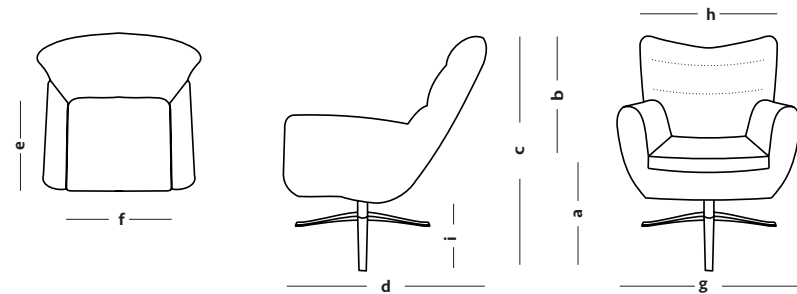

# MOON



a	b	c	d	(cm)
93	90	45	63	

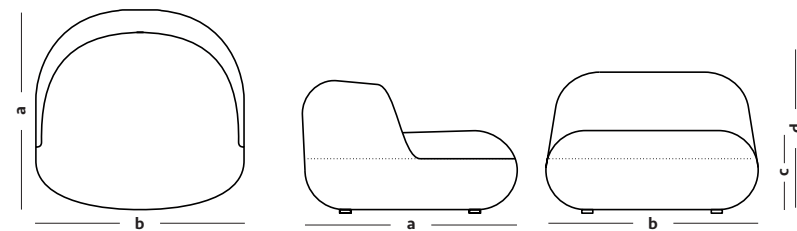

# PUFF

NEW

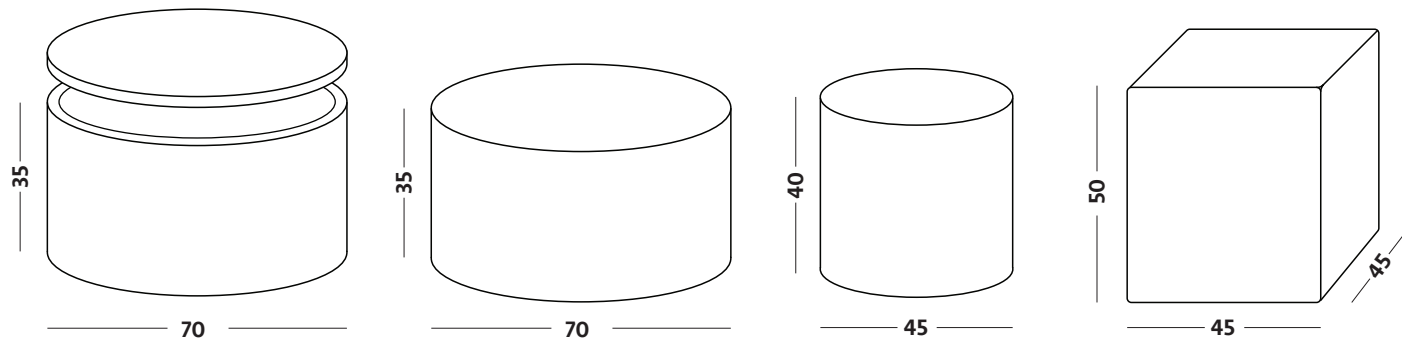

NAEL

MONI

OLI

TINA

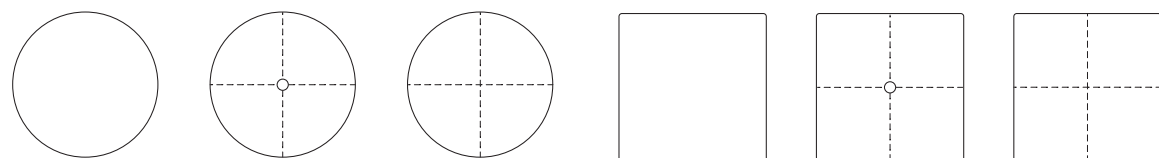

No. 1

No. 2

No. 3

No. 1

No. 2

No. 3



NEW



# BOUDOIR BREEZE

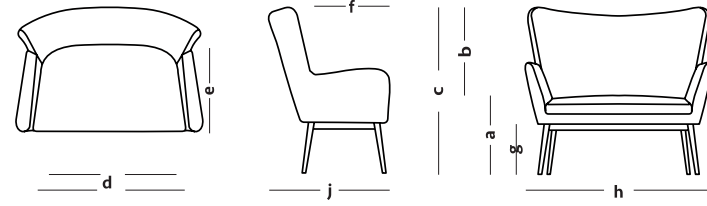

	a	b	c	d	e	f	g	h	j	(cm)
<b>CROSS</b>	45	53	98	116 100	56	54	31	140	84	

# BREEZE

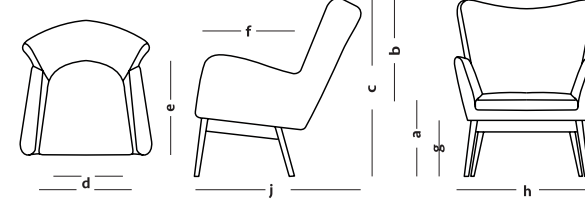

	a	b	c	d	e	f	g	h	j	(cm)
<b>CUT</b>	45	63	94	56 42	56	42	26 31	78	85	
<b>CROSS</b>	45	63	102	56 42	56	42	32	78	80	

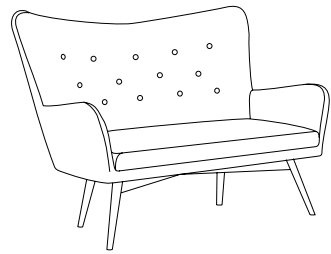

Button

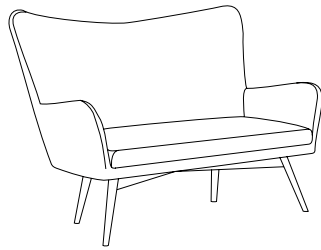

Clean

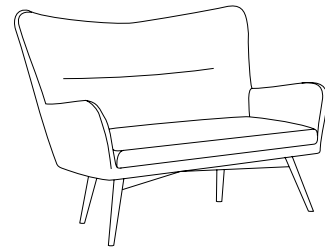

Mirach

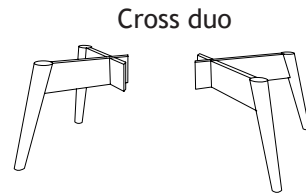

Cross duo

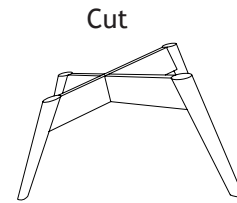

Cut

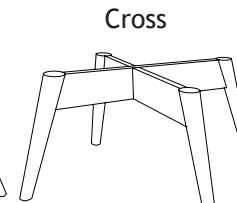

Cross

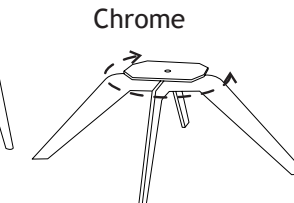

Chrome

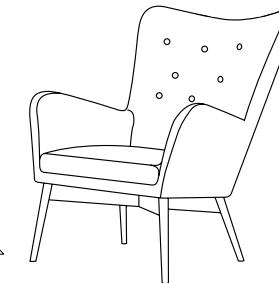

Button

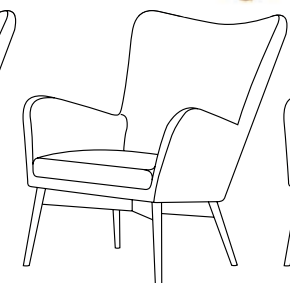

Clean

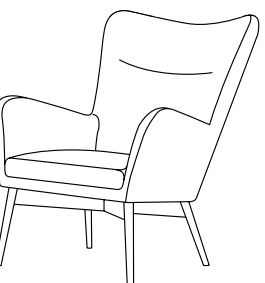

Mirach



# DE LUXE

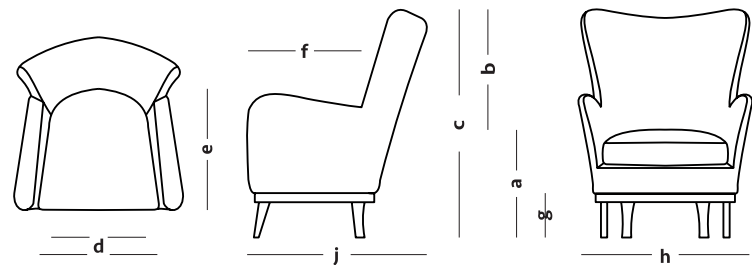

	a	b	c	d	e	f	g	h	j	(cm)
<b>CASTEL</b>	45	55	100	56   42	54	49	20	79	80	
<b>LINE</b>	46	55	101	56   42	54	49	21	79	80	

# MODERN

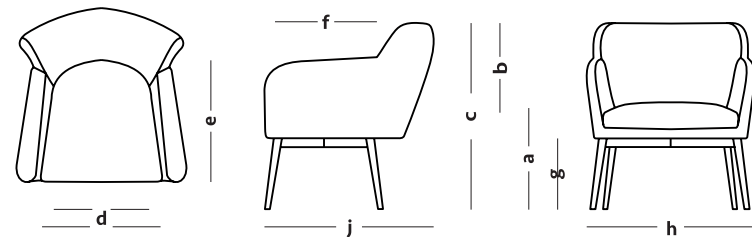

	a	b	c	d	e	f	g	h	j	(cm)
<b>CUT</b>	45	33	69	55   44	56	42	26   31	75	79	
<b>CROSS</b>	45	33	78	55   44	56	42	32	75	75	

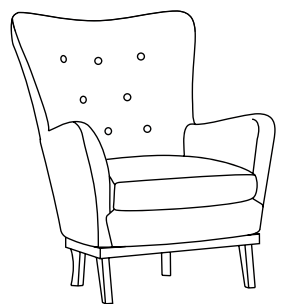

Button

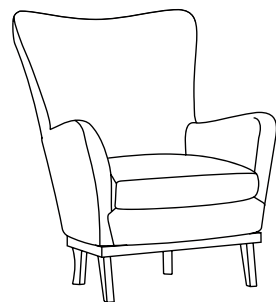

Clean

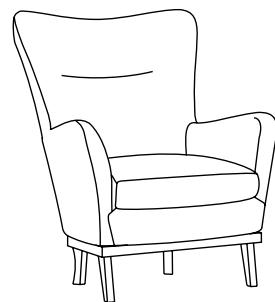

Mirach

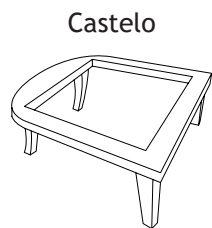

Castelo

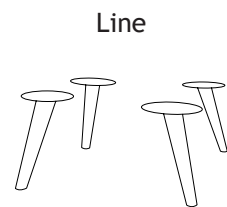

Line

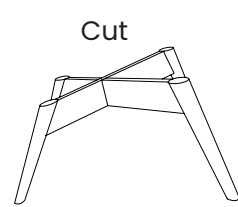

Cut

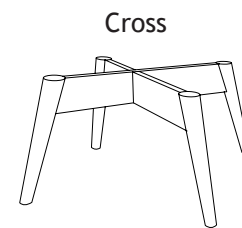

Cross

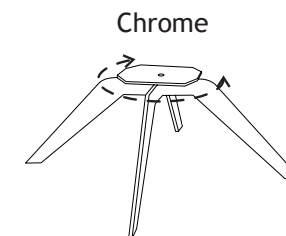

Chrome

CUT

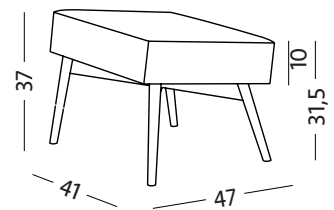

CASTELO

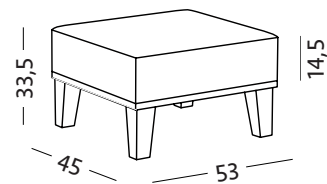

CROSS

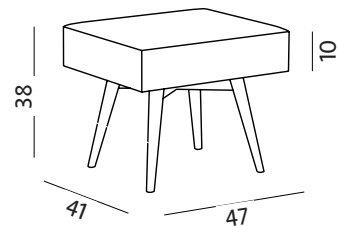

INDUSTRY

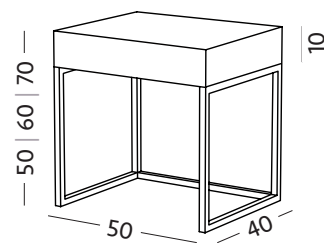

HEAVY OAK

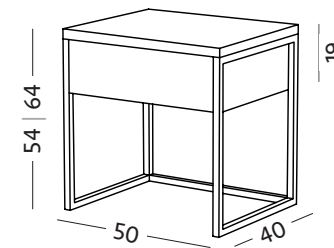

OAK

NEW

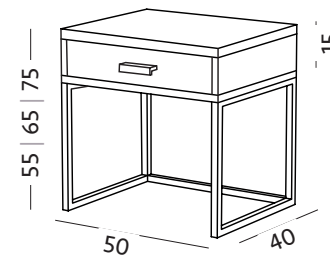

WHITE

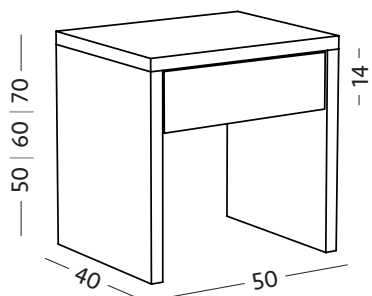

STONE

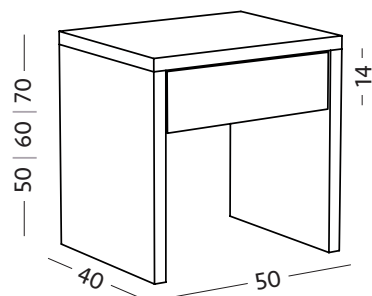

DARK STONE

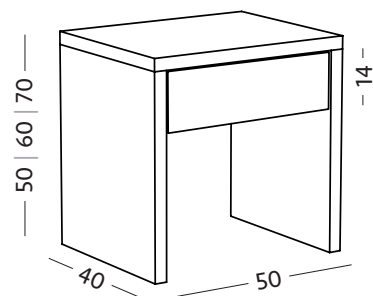

CUBE

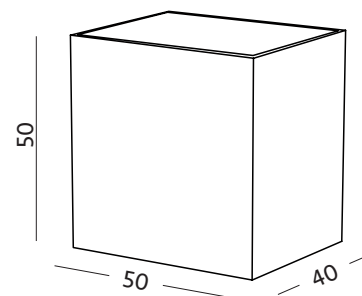

DAMIANI

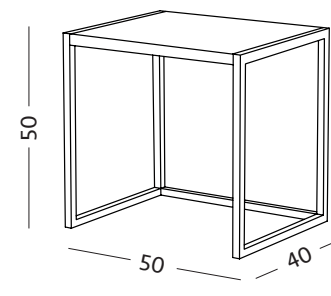

BIANCA

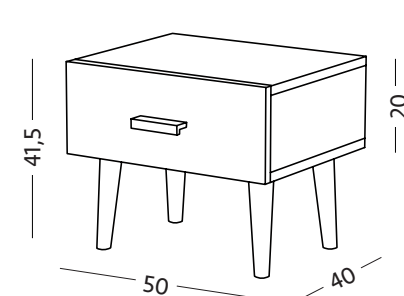

# TABURET | BENCH

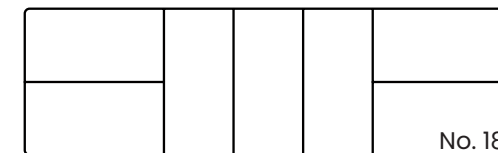
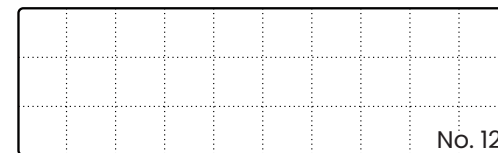
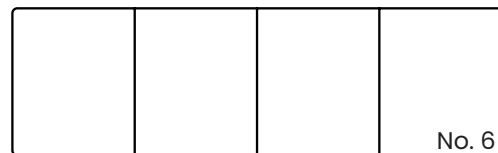
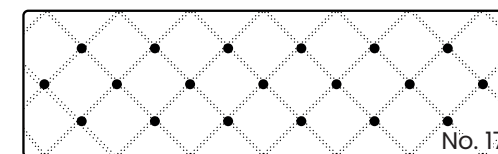
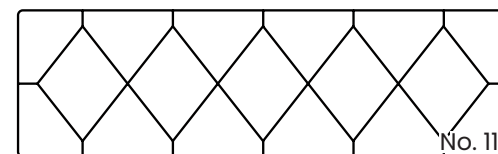
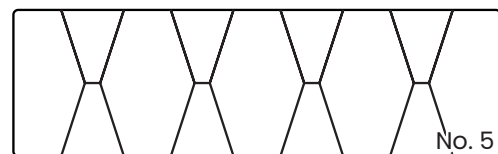
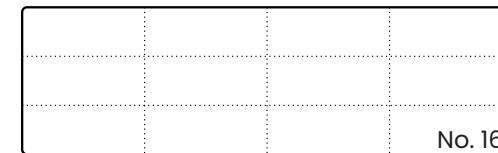
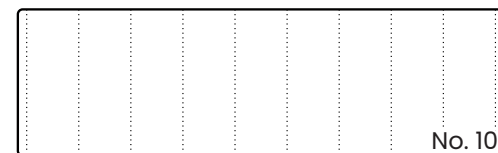
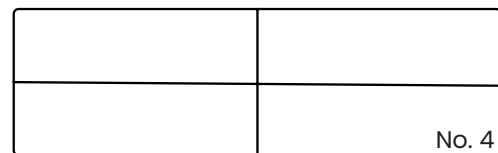
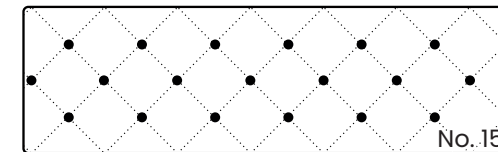
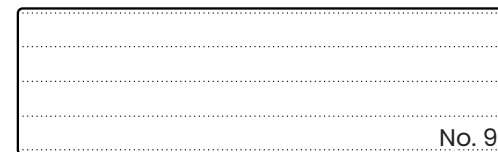
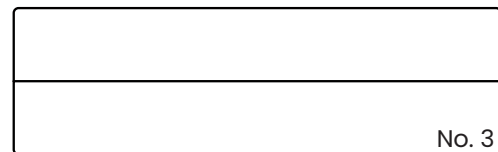
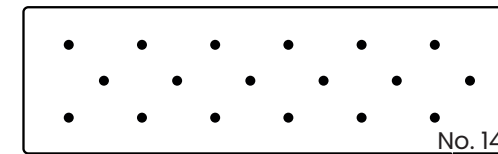
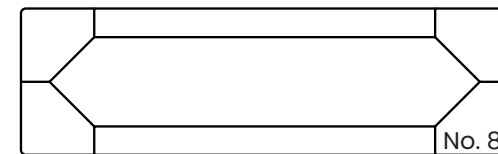
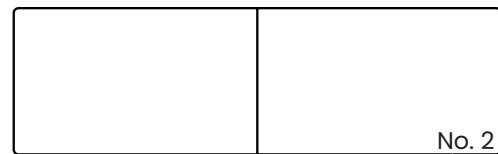
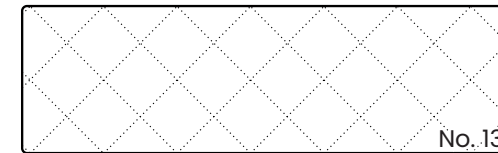
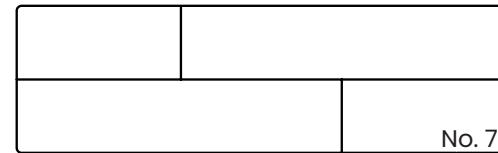
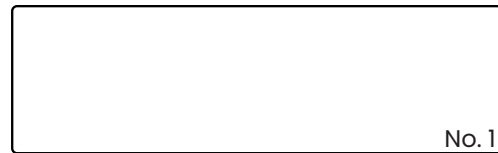
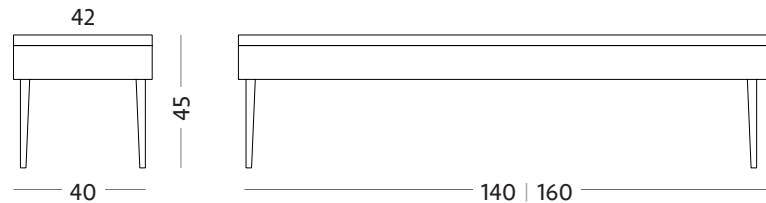
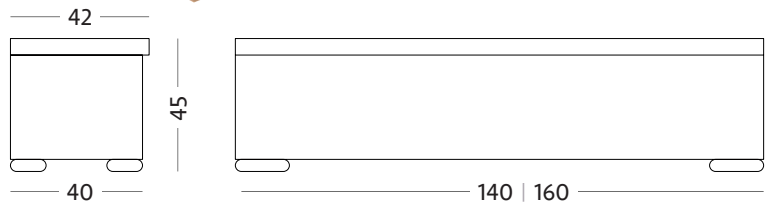

NEW



Flute

120 | 150 | 190 mm - black, bronze, chrome, gold

NEW



Line

120 | 150 | 220 mm - chrome, black, white

NEW



Light

150 mm - black



NEW

Floor angle

200 × 200 × 20 mm - chrome

NEW



Floor tube

200 mm × 32 mm - chrome



Floor

150 × 150 × 30 mm - chrome

NEW



Capri

200 mm - black | 190 mm - chrome

NEW



Dual

150 mm - black

NEW



Spider

120 | 150 mm - chrome



Fancy

130 mm - chrome



Industry

130 mm - black



Elegance

130 mm - black, white, chrome, gold



Polygon

100 mm - chrome



Metal

80 mm - chrome



NEW



**Block ·**

100 | 130 | 160 mm – natur, walnut, gray, wenge, black



**Wood 1**

88 | 100 | 130 mm – natur, gray, walnut, wenge, black



**Tulip**

130 mm – natur



**Castello**

130 mm – walnut



**Cube**

100 mm – cherry



**Wood 2**

80 mm – natur, walnut, gray, wenge, black



**Wood 4**

110 mm – natur, walnut, gray, wenge, black



**Wood 5**

110 mm – natur, walnut, gray, wenge, black

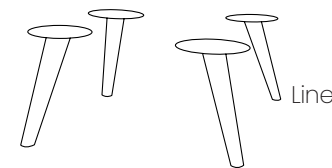

Line

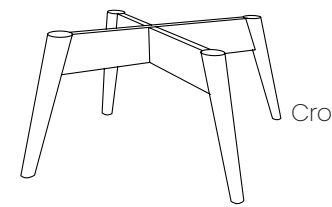

Cross

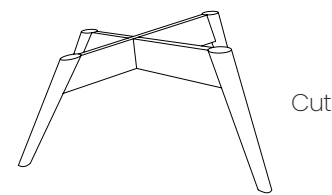

Cut

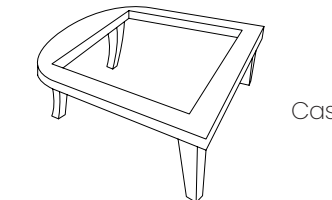

Castello

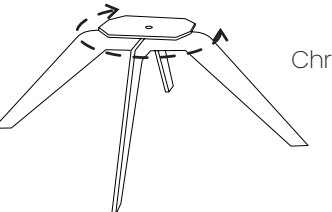

Chrome



Natur

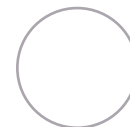

White

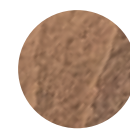

Walnut

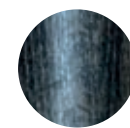

Wenge



- SK** Obsah katalógu je duševným vlastníctvom firmy Materasso Slovakia s. r. o. Použit' tieto materiály je možné len s uvedením ich vlastníka: © Materasso Slovakia s. r. o. Nedodržanie týchto podmienok je právne **vymáhateľné ako porušenie autorských práv**. Farby použitých materiálov sú ilustračné, môžu byť odlišné od skutočnosti.
- CZ** Obsah katalogu je duševním vlastníctvím firmy Materasso Slovakia s. r. o. Použit' tyto materiály lze pouze s uvedením jejich vlastníka: © Materasso Slovakia s. r. o. Nedodržení těchto podmínek je právně **vymáhateľné jako porušení autorských práv**. Barvy použitých materiálů jsou ilustrační, mohou být odlišné od skutečnosti.
- EN** The content of the catalogue is the intellectual property of Materasso Slovakia s. r. o. It is possible to use these materials only with the indication of their owner: © Materasso Slovakia s. r. o. Failure to comply with these terms and conditions is legally **enforceable as copyright infringement**. The colors of the materials used are illustrative, they may differ from the actual ones.
- PL** Zawartość katalogu jest własnością intelektualną Materasso Slovakia s. r. o. Korzystanie z tych materiałów jest możliwe tylko za wskazaniem ich właściciela: © Materasso Slovakia s. r. o. Nieprzestrzeganie tych warunków jest prawnie **egzekwowalne jako naruszenie praw autorskich**. Kolory użytych materiałów mają charakter poglądowy, mogą różnić się od rzeczywistych.
- HU** A katalógus tartalma a Materasso Slovakia s. r. o. szellemi tulajdonát képezi. Ezeket az anyagokat csak a tulajdonos feltüntetésével lehet felhasználni: © Materasso Slovakia s. r. o. E feltételek be nem tartása jogilag **érvényesíthető szerzői jogsértésként**. A felhasznált anyagok színei illusztrációs célokat szolgálnak, és eltérhetnek a valóságtól.
- DE** Der Inhalt des Katalogs ist geistiges Eigentum von Materasso Slovakia s. r. o. Die Nutzung dieser Materialien ist nur mit Angabe des Eigentümers möglich: © Materasso Slovakia s. r. o. Die Nichteinhaltung dieser Bestimmungen und Bedingungen kann als **Urheberrechtsverletzung rechtlich verfolgt werden**. Die Farben der verwendeten Materialien sind illustrativ, sie können von den tatsächlichen abweichen.

m  
Materasso  
[www.materasso.pl](http://www.materasso.pl)  
2025

